

Maße/Dimensions Schieber Serie AT 200 mit E-Antrieb Knife gate valve series AT 200 with electric actuator SA 10.2 - 16.2 DN 350 – DN 1200

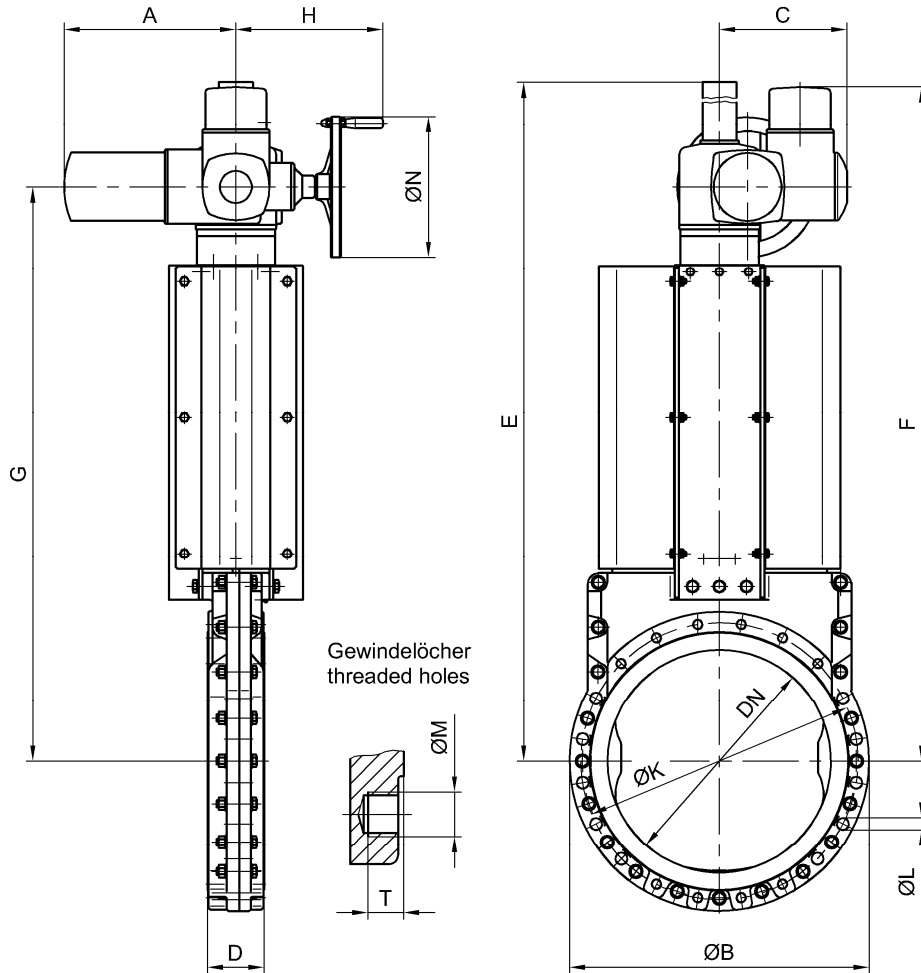

DN	NPS	Antrieb actuator	PB	A	ØB	C	D	E	F	G	H	ØK	ØL	ØM	T	ØN	kg
350	14"	SA 10.2	6	283	505	248	78	1371	1241	1031	254	460	8xØ22	8xM20	18	200	165
400	16"	SA 10.2	6	283	565	248	102	1457	1277	1067	254	515	8xØ27	8xM24	26	200	200
450	18"	SA 10.2	4	283	615	248	114	1652	1422	1212	254	565	10xØ27	10xM24	26	200	240
500	20"	SA 14.2	4	389	670	286	127	1724	1494	1268	336	620	10xØ27	10xM24	26	315	310
600	24"	SA 14.2	4	389	780	286	154	1977	1697	1421	336	725	10xØ30	10xM27	35	315	440
700	28"	SA 14.6	4	389	895	286	165	2318	1888	1662	339	840	12xØ30	12xM27	39	400	700
800	32"	SA 14.6	4	389	1015	286	190	2603	2073	1847	339	950	12xØ33	12xM30	49	400	960
900	36"	SA 16.2	3	430	1115	303	203	2973	2378	2148	365	1050	14xØ33	14xM30	43	500	1350
1000	40"	SA 16.2	2,5	430	1230	303	216	3233	2538	2308	365	1160	14xØ36	14xM33	45	500	1600
1200	48"	SA 16.2	2	430	1455	303	254	3785	2890	2660	365	1380	16xØ39	16xM36	55	500	2300

Maße bezogen auf AUMA Standard-Stellantrieb. Geänderte Maße bei anderem Antriebstyp.
 Dimensions based on AUMA standard electric actuator. Dimensions change if other actuators are used.

PB [bar] = max. Betriebsdruck / max. working pressure

Max. Differenzdruck bei Betätigung:
 Max. differential pressure during operation:

DN	Druck / pressure
350-1000	2,5 bar
1200	1,0 bar

Änderungen vorbehalten
 subject to changes