



Worcester Controls C44 Cryogenic 3-Piece Ball Valves



Experience In Motion



Contents

| | |
|--|-----|
| Overview | 2-3 |
| Parts/Materials | 4 |
| Valve Dimensions | 5 |
| Throttling Control of Cryogenics | 6 |
| Other Cryogenic Products | 7 |

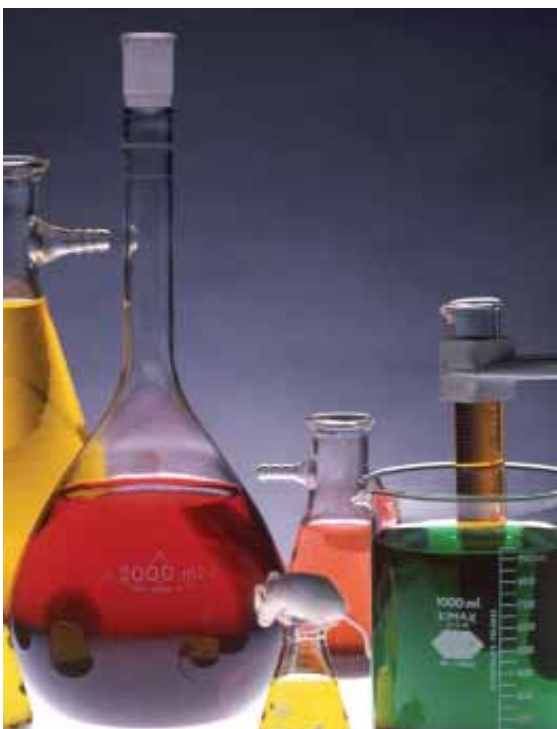

Cryogenic Valve Design

Flowserve Worcester's experience and expertise in the design of cryogenic ball valves has been recognised throughout the process industry for over 30 years. Utilising a combination of our Fluorofill seat material and our unique 'S' gasket body seal, the valve provides positive shut-off in the most demanding of cryogenic applications. From the original C44 R5 and MC44 designs the seat and body seals have remained a constant feature and with both products now rationalised into the C44 R7, additional technical advantages have been included to provide what is considered the best cryogenic ball valve on the market.

The Worcester 3-piece ball valve offers a number of technical advantages over other types of valve.

Tested and certified to EN1626 and can be used on TPED CATIII applications.

High Flow Rate

The high Cv available from a ball valve compared with a globe valve makes the C44 ideal for loading stations where speed of delivery is critical. The valve is also available as fullbore up to DN40 as the C59 series.

Low Body Mass

The one-piece design minimises the mass of the body and therefore makes the valve economic to use. It also provides a weight advantage, making the valve ideal for road tankers and other transportation requirements.

Ease of Operation

The unique low torque seat design and the 90 degree operation of the ball valve makes it ideal for use with both pneumatic and electric actuators with the additional benefit of rotary control if required. When manually operated, the lever provides visual indication of the valve orientation (open or closed) which is critical in the safe loading and unloading of liquid gases.

Ease of Maintenance

The 3-piece concept provides the benefit of easy maintenance through the "slide out" body method.



- **Automation** - Solid actuator mounting platform for on/off and control applications
- **Stem** - One piece anti-blowout design with ball relief hole position indication
- **Packing** - Chevron design for optimum sealing life consisting of a PTFE chevron seal captured between 2 graphite chevron seals.
- **Extension** - minimal gap to reduce frost line and minimise heat transfer
- **Body** - One piece design provides optimum strength and low body mass
- **Ball** - With cavity pressure relief hole and fool-proof stem alignment device
- **'S' Gasket** - 316 coated PTFE to compensate for thermal fluctuations
- **Seat** - Low torque design manufactured in Fluorofill PTFE

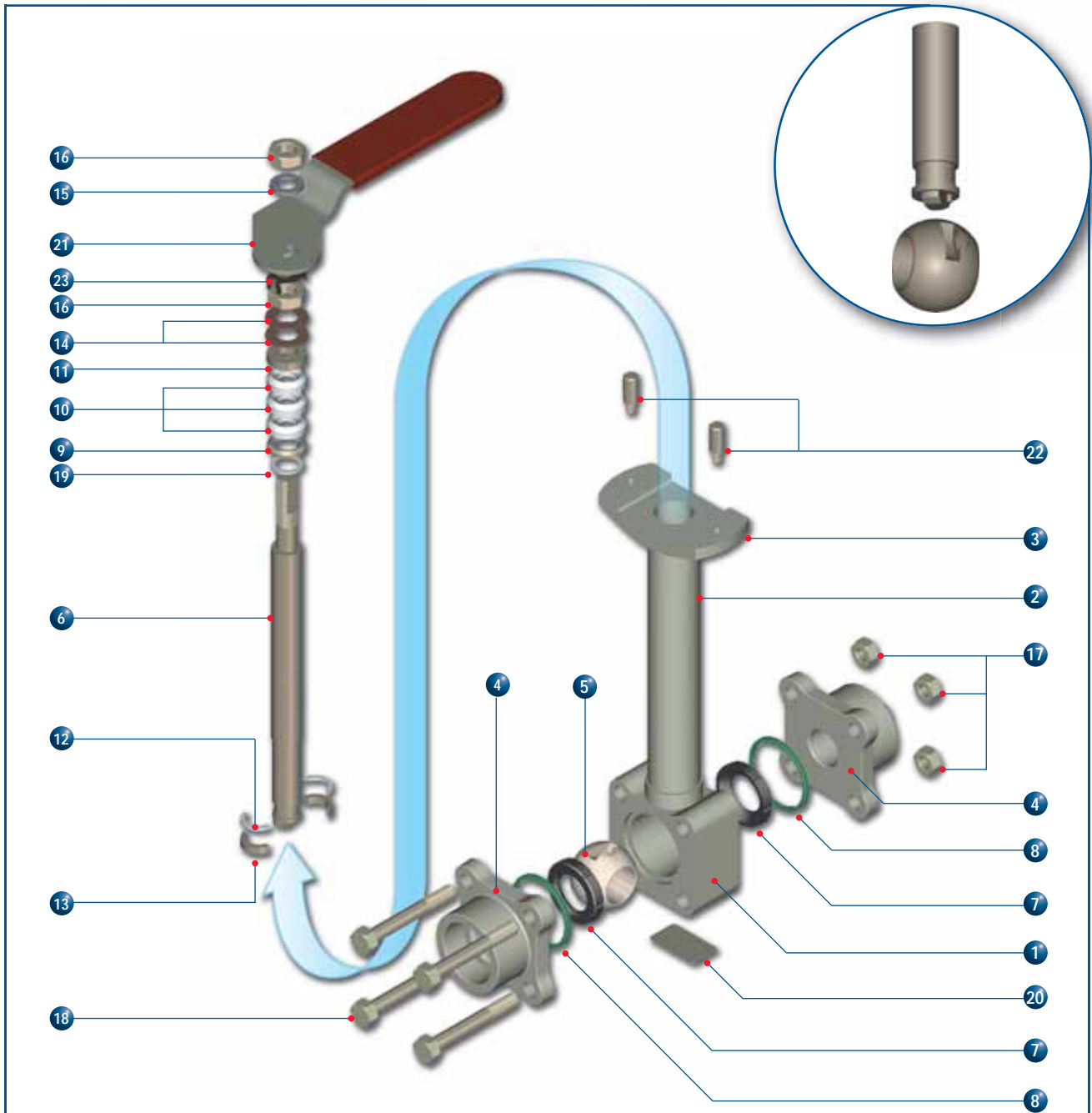

Parts/Materials List

| ITEM | DESCRIPTION | MATERIAL | ITEM | DESCRIPTION | MATERIAL |
|------|---------------------------|--|------|-------------------------------|---|
| 1. | Body | Stainless Steel ASTM A351/CF3M Brass ASTM B283 C37700 | 12. | Split Thrust Bearing (Halves) | Polyfill |
| 2. | Extension | Stainless Steel ASTM A312/316L | 13. | Split Ring (Halves) | Stainless Steel ASTM A479/316L |
| 3. | Bonnet Plate | Stainless Steel ASTM A743/CF3M | 14. | Belleville Washer | Stainless Steel AISI 301 |
| 4. | Pipe End | Stainless Steel ASTM A351/CF3M Brass BS2872 CZ122 | 15. | Spring Washer | Stainless Steel AISI 300 Series |
| 5. | Ball | Stainless Steel ASTM A479/316 Cond. A | 16. | Stem & Wrench Nut | Stainless Steel AISI 300 Series/Zinc Plated |
| 6. | Stem Assembly | Stainless Steel ASTM A479/316 Cond. A | 17. | Body Nut | Stainless Steel ASTM A194 Gr.8 |
| 7. | Seat | Fluorofill | 18. | Body Bolt | Stainless Steel ASTM A193 Gr.B8/ENP |
| 8. | Body Seal | Stainless Steel AISI 316/TFE Coated | 19. | Thrust Bearing | Fluorofill |
| 9. | Packing Follower (Bottom) | Stainless Steel ASTM A479/316L | 20. | Nameplate | Stainless Steel AISI 304 |
| 10. | Packing Ring | Crane Chemlon V-Ring/Teflon | 21. | Wrench/Sleeve Assembly | St. Steel AISI 300 Series/Vinyl Coated |
| 11. | Packing Follower (Top) | Stainless Steel ASTM A479/316L | 22. | Stop Pin | Stainless Steel AISI 300 Series |
| | | | 23. | Locking Clip | Carbon Steel Plated |

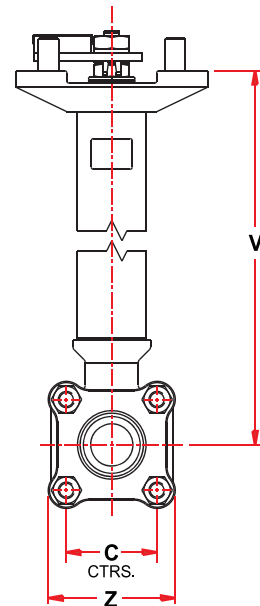
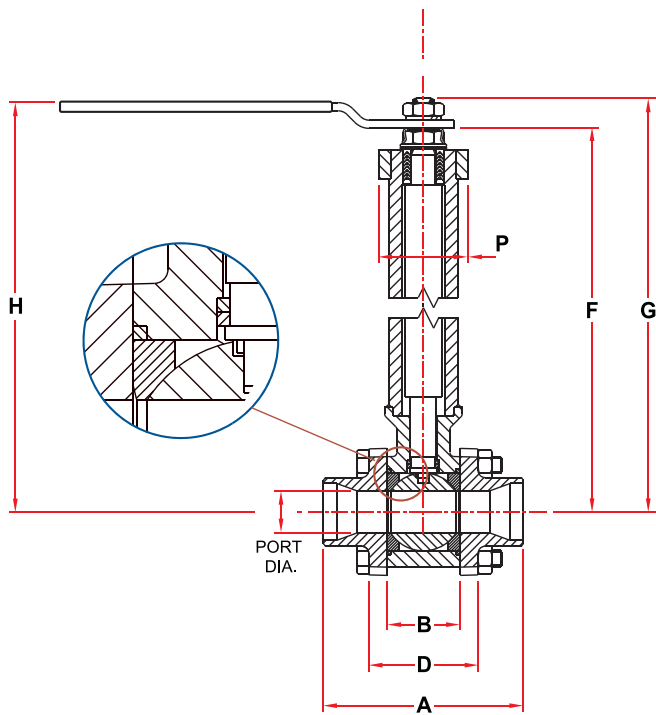
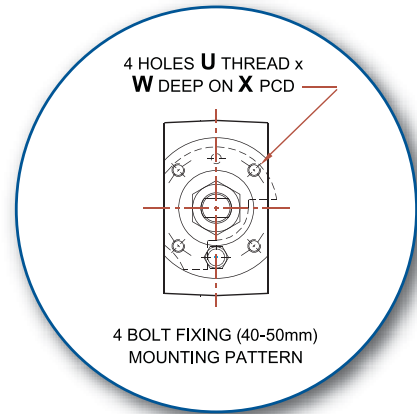
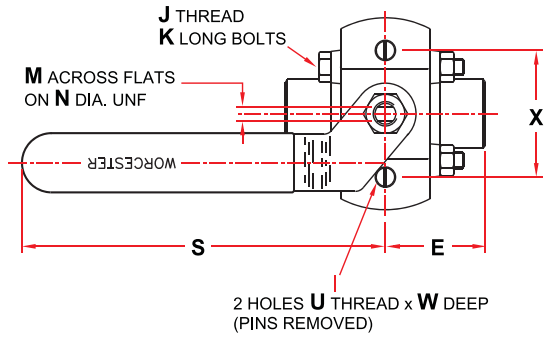

Valve Dimensions

| Valve Size (mm) | Port Dia. | A | B | C | D | E | F | G | H | J | K | M Max. | N | S | U | V | W | X | Z | Approx. Weight (kg) |
|-----------------|-----------|-------|-------|------|------|------|--------|--------|-------|-----|----|--------|---------|-------|----|-------|-----|------|------|---------------------|
| DN15 | 11.1 | 65.4 | 20.58 | 31.8 | 31.8 | 32.7 | 184.21 | 199.64 | 199.9 | M6 | 40 | 7.5 | 7/16-20 | 165.1 | M6 | 175.8 | 9.5 | 63.5 | 47.6 | 1.4 |
| DN20 | 14.3 | 71.0 | 24.55 | 38.1 | 37.4 | 35.5 | 186.75 | 202.18 | 202.5 | M6 | 45 | 7.5 | 7/16-20 | 165.1 | M6 | 178.3 | 9.5 | 63.5 | 54.4 | 1.6 |
| DN25 | 20.6 | 93.7 | 31.69 | 44.5 | 49.3 | 46.9 | 201.88 | 226.31 | 227.1 | M8 | 60 | 7.5 | 7/16-20 | 165.1 | M6 | 202.5 | 9.7 | 63.5 | 65.4 | 2.3 |
| DN40 | 31.8 | 114.6 | 48.35 | 57.2 | 69.6 | 57.3 | 241.83 | 259.84 | 264.8 | M10 | 80 | 8.67 | 9/16-18 | 181.0 | M6 | 230.9 | 8.7 | 50.0 | 80.3 | 5.0 |
| DN50 | 38.1 | 127.1 | 56.28 | 66.7 | 79.1 | 63.6 | 246.40 | 264.41 | 269.4 | M10 | 90 | 8.67 | 9/16-18 | 181.0 | M6 | 235.5 | 8.7 | 50.0 | 90.4 | 5.9 |

Throttling Control of Cryogenics

The Worcester V-Flow provides positive shut-off with accurate control by utilising a cryogenic flourofill seat downstream and a metal profiled seat upstream. The choice of seat profile on the upstream seat is dependent on the flow conditions required. The V-Flow is ideally suited for either electric actuation using a

75 series Norbro DataFlo P or pneumatic 40R series with a PMV positioner.

The combination of the V-Flow with the cryogenic C44 design provides an ideal cryogenic control valve for a variety of applications from food freezing to high purity gases.

Upstream Seat Selection (some typical examples)

The relationship between ball position and characterised seat allows for precision throttling control. The V-Flow control valves are sized to ideally control between 20 - 80% opening of the valve.

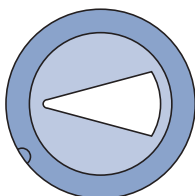

30° Seat
(equal percentage)

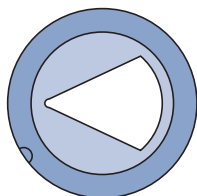

60° Seat
(equal percentage)

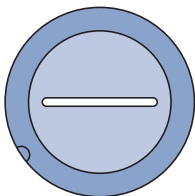

Slotted Seat
(linear characteristic)

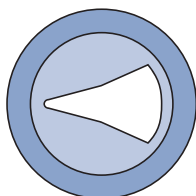

Custom Seats
(special applications)



Flow Characteristic Options

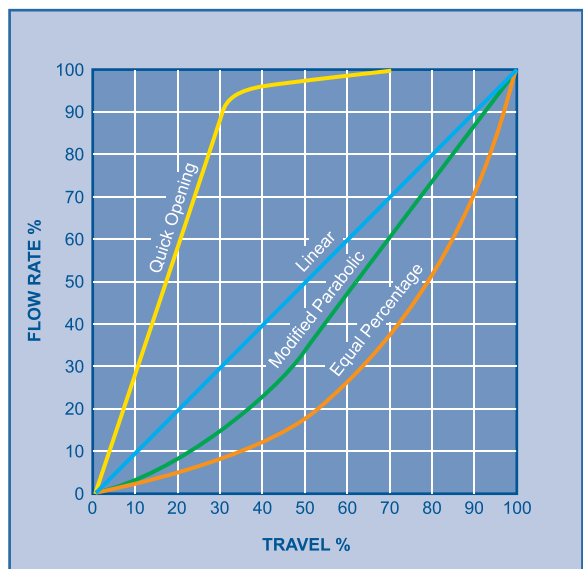

Other Cryogenic Products

CF51/52



For petrochemical requirements the CF51/52 firesafe cryogenic valve is available utilising the same ball and seats as used in the C44 valve.

DC13



Using the C44 concept for diverting flow, the DC13 is a 90 degree operation valve.

CB18



The cryogenic version of our B18 provides a true multi-port design.

VC44



For control of liquid gases the VC44 valve utilises the profiled metal seat from the proven V-Flow control valve (see p6).

CN44



For non-continuous cryogenic applications, the CN44 (non-extended) is ideal for drains on cryogenic lines. The valve contains the same ball, seats and body seals as the C44.

C59



The cryogenic valve is also available as full bore up to 40mm bore for applications where high flow rates are required.

Pressure/Temperature Ratings

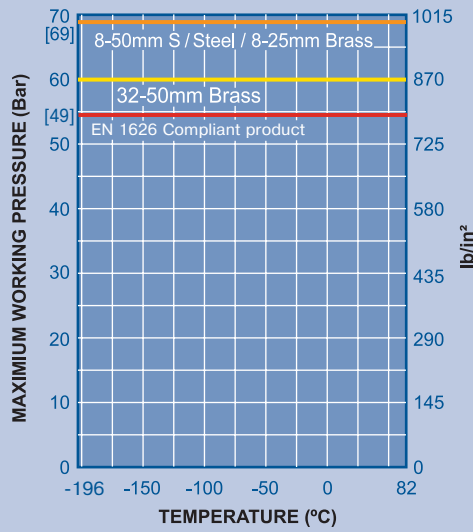

Notes

1. Screwed, butt weld and socket weld variations are available.
2. When wrench not fitted, flats on stem, when parallel to pipeline axis, denote ball open.
3. All weld end valves are assembled with 'S' gasket ring body connector seals with additional seals attached loose. This provides for the valve to be tested by Worcester Controls, disassembled by the customer to weld inline, and reassembled-Instructions will be supplied for fitting body seals.
4. All valves are built in a clean room and are suitable for oxygen service.
5. Installation. Operating and Maintenance Instructions supplied with the product and are also available on request.
6. Installation. Stem to be installed 45° max from vertical.

Standards of Compliance

| | |
|--------------------|---|
| Butt Weld Valves | Weld Preparation: SCH 40 & 10: BS 2633 suitable for Schedule Pipe to BS 1600 |
| Socket Weld Valves | Prepared for assembly to plain end pipe in accordance with BS 1600 |
| Screwed Valves | Threaded Specification: BSP Taper - BS21/ EN 10226-1 BSP Parallel - ISO 228/1 NPT - ASNI B1.20.1 |
| Test Rating | Valves are subjected to the requirements of EN 12266-1 EN1626 (Valves for Cryogenic service) |

Technical Information

| Valve Size | | Flow Coefficients | | Equivalent Length of Pipe | |
|------------|-----|-------------------|------|---------------------------|--------|
| mm | in | Cv | Kv | Feet | Metres |
| 8-15 | ¼-½ | 8.3 | 7.2 | 1.9 | 0.58 |
| 20 | ¾ | 13.6 | 11.8 | 5.5 | 1.67 |
| 25 | 1 | 37.5 | 32.6 | 3.0 | 0.91 |
| 32 | 1¼ | 37.7 | 32.7 | 4.6 | 1.4 |
| 40 | 1½ | 79.5 | 69.1 | 3.9 | 1.19 |
| 50 | 2 | 106 | 92 | 9.0 | 2.28 |

Cv – Flow in US GPM Pressure – psi
Kv – Flow in M³/hr Pressure – bar

Typical Applications

- Road tankers
 - Terminal unloading stations
 - Food freezing systems
 - High purity cryogenic gas systems
 - Steel production plants
 - LN₂ and CO₂ storage vessels
- and many other services and applications



All valves are built in the clean room and are suitable for oxygen service.

FCD WCEBR0013-02 Printed in Germany. (Replaces PB06 Rev 11/02)

To find your local Flowserve representative:

For more information about Flowserve Corporation, visit www.flowserve.com or call USA 1 800 225 6989



Flowserve Flow Control

A Division of Flowserve GB Ltd
Burrell Road, Haywards Heath
West Sussex RH16 1TL
United Kingdom
Telephone: +44 (0)1444 314400
Telefax: +44 (0)1444 314401
Email: wvukinfo@flowserve.com

Due to continuous development of our product range, we reserve the right to alter the dimensions and information contained in this leaflet as required. Information given in this leaflet is made in good faith and based upon specific testing but does not, however, constitute a guarantee.