

Maße Processklappe Serie KG6 Dimensions butterfly valve series KG6 DN 40 - DN 300

Baulänge: EN 558-1 Reihe 20 (DIN 3202-K1) Face to face dimension: EN 558-1 line 20 (DIN 3202-K1)

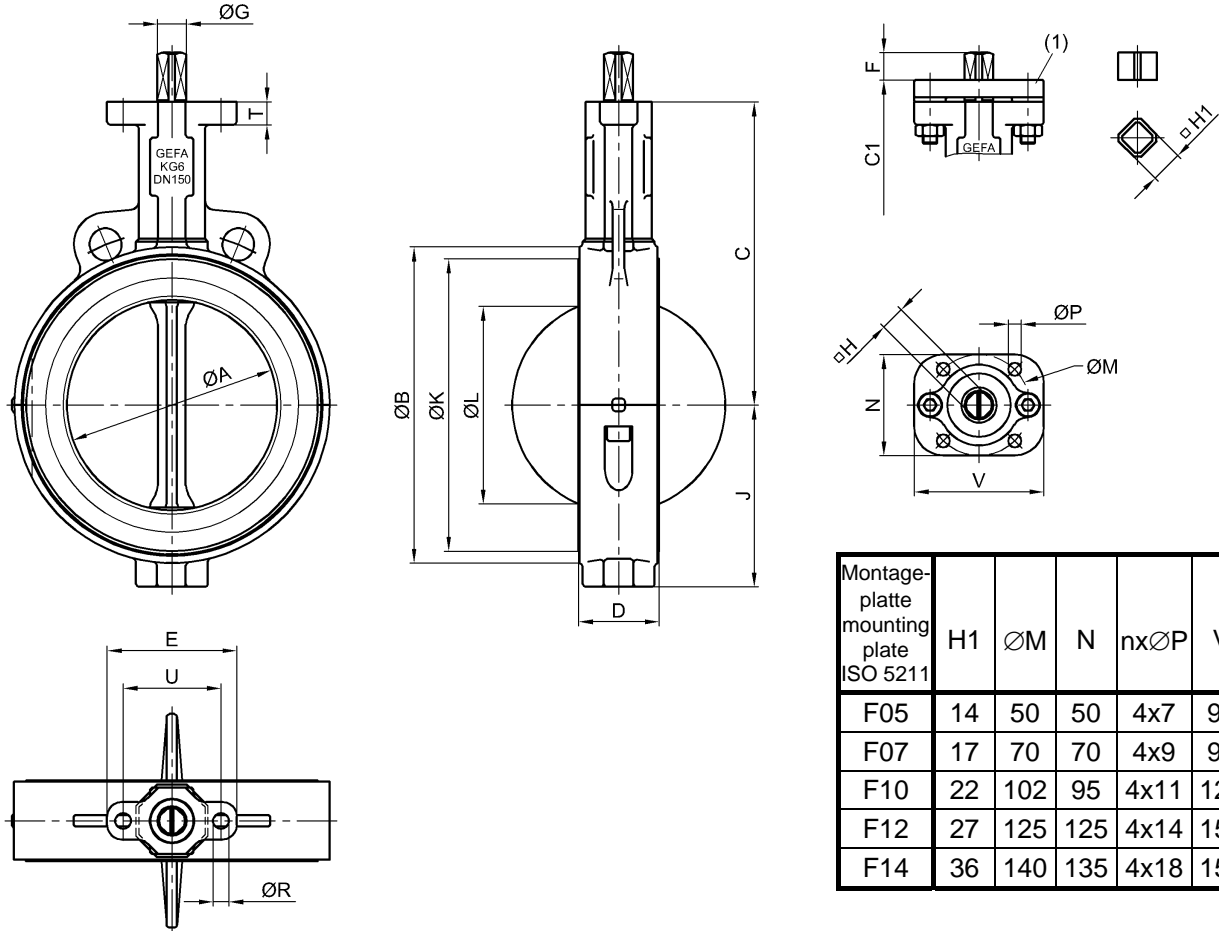

Montage- platte mounting plate ISO 5211	H1	ØM	N	nxØP	V
F05	14	50	50	4x7	90
F07	17	70	70	4x9	90
F10	22	102	95	4x11	125
F12	27	125	125	4x14	150
F14	36	140	135	4x18	150

(1) MULTITOP Montageplatte und Vierkant-Adapter zum Direktaufbau von Antrieben mit größerem Anschlussflansch. Sonderaufbauten möglich.

(1) MULTITOP mounting plate and square-adapter for direct mounting of actuators with larger connection flange. Special designs possible.

ØK = Sitzring-Außendurchmesser / Seat outside diameter

ØL = kleinster Flanschinnendurchmesser / smallest inside diameter of flange

DN	NPS	ØA	ØB	C	C1	D	E	F	ØG	H	J	ØK	ØL	ØR	T	U	kg	kleinster Anschluss min. mounting plate DIN 3337/ISO 5211
40	1 1/2"	52	93	130	145	43*	90	16	14	11	60	86	33	11	14	68	2,4	F05
50	2"	52	100	130	145	43	90	16	14	11	60	86	33	11	14	68	2,4	F05
65	2 1/2"	64	111	145	160	46	90	16	14	11	67	97	48	11	14	68	2,9	F05
80	3"	77	136	160	175	46	90	16	14	11	75	122	64	11	14	68	3,6	F05
100	4"	103	163	180	195	52	90	16	16	14	94	147	92	11	16	68	5,2	F07/SW14
125	5"	127	193	195	210	56	90	19	20	17	113	176	117	11	16	68	7,7	F07
150	6"	146	219	210	225	56	90	19	20	17	126	203	137	11	16	68	9,4	F07
200	8"	198	274	240	258	60	125	19	22	17	158	260	191	13	21	95	14	F10
250	10"	247	328	270	288	68	125	24	28	22	191	313	240	13	21	95	21	F10
300	12"	299	377	300	318	78	125	24	28	22	222	363	290	13	21	95	31	F10

*GEFA Baulänge / GEFA face to face dimension

Weight without mounting plate

Änderungen vorbehalten
subject to changes

Processklappe Serie KG6 bis KG9 mit Handhebel

Butterfly valve series KG6 to KG9 with hand lever

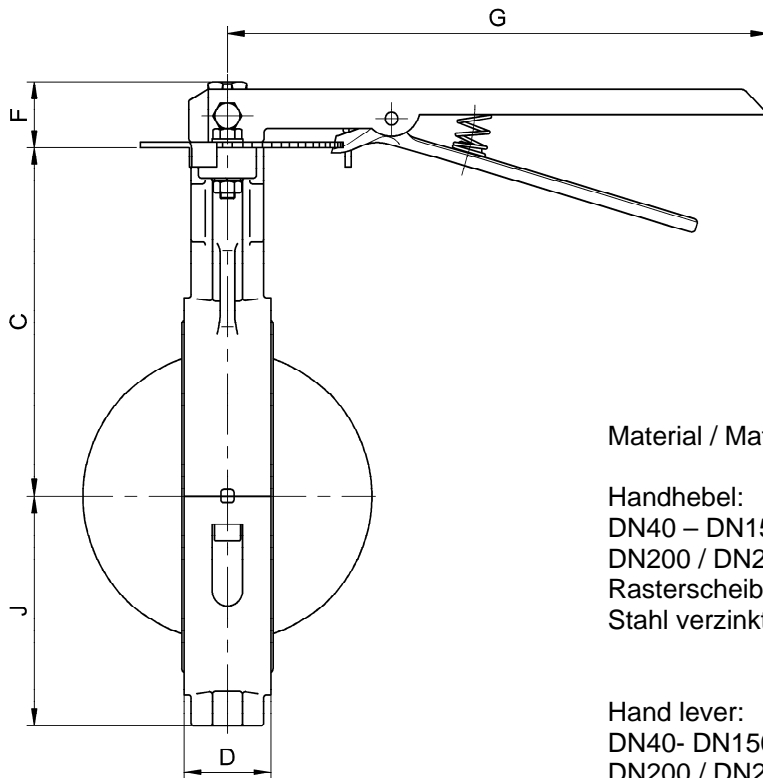

Material / Materials

Handhebel:
 DN40 – DN150: Aluminium oder Edelstahl
 DN200 / DN250: Aluminium
 Rasterscheibe:
 Stahl verzinkt oder Edelstahl

Hand lever:
 DN40- DN150: Aluminium or stainless steel
 DN200 / DN250: Aluminium
 Notch plate:
 Steel zinced or stainless steel

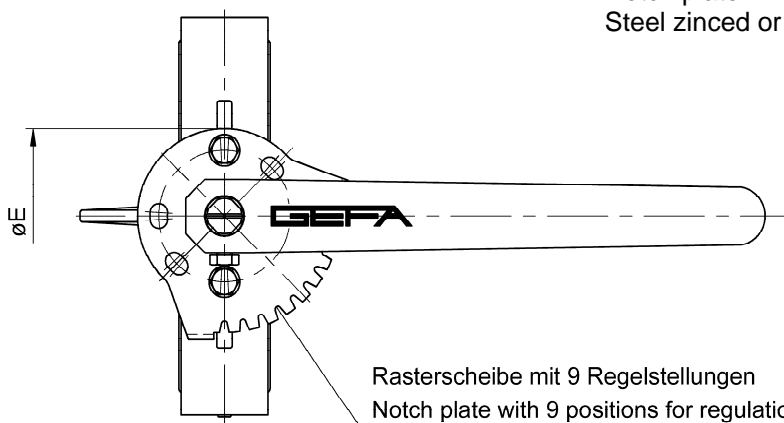

Rasterscheibe mit 9 Regelstellungen
 Notch plate with 9 positions for regulation

DN	NPS	C	D	ØE	F	G	J	kg *
40 / 50	1 1/2" / 2"	130	43	90	30	280	60	0,6 / 1,1
65	2 1/2"	145	46				67	
80	3"	160	46				75	
100	4"	180	52				94	
125	5"	195	56				113	
150	6"	210	56				126	
200	8"	240	60	125	38	340	158	1,0
250	10"	270	68				191	

* Gewicht Handhebel inklusive Zubehör

* Weight of hand lever including accessories

Änderungen vorbehalten
 subject to changes

Processklappe Serie KG6 bis KG9 mit Aluminium Getriebe Butterfly valve series KG6 to KG9 with aluminium gear operator DN 40 - DN 300

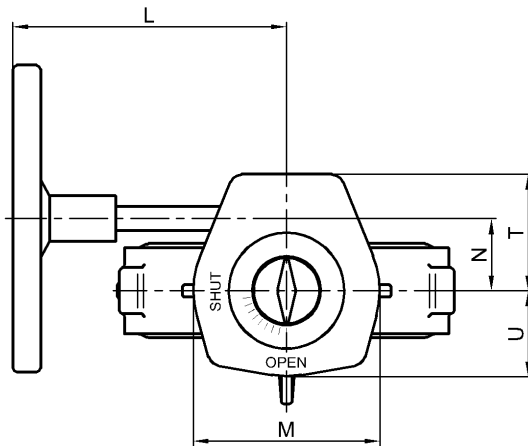
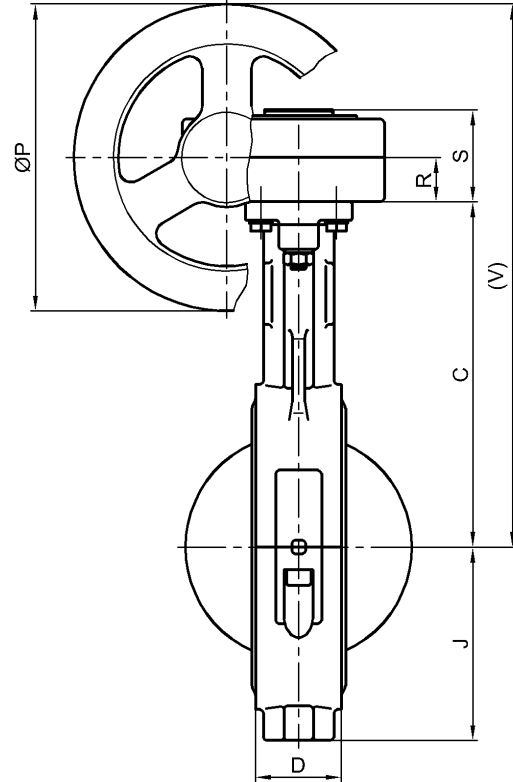
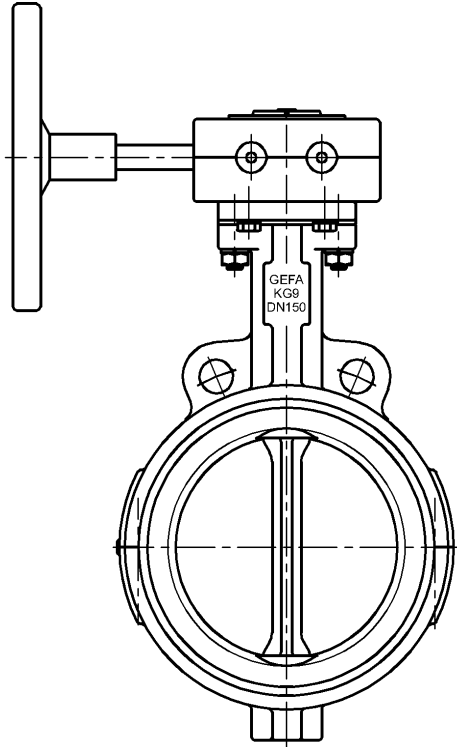

Getriebewerkstoffe / Gear materials
 Gehäuse / Body: Aluminium / aluminium
 Welle / Stem: Stahl / steel
 Handrad / Handwheel: Stahl / steel

Gewicht des Getriebes inklusive Handrad.
 Klappenspezifische Daten entnehmen Sie bitte
 den entsprechenden Datenblättern.

Weight of gear operator including handwheel.
 Regarding valve data please refer to relevant
 data sheets.

DN	NPS	Getriebe Typ Gear type	C	D	J	L	M	N	ØP	R	S	T	U	V	kg
40 / 50	1 1/2" / 2"	BGM98111V	145	43	60	150	113	39	125	31	71	64	56	239	2,0
65	2 1/2"	BGM98111V	160	46	67	150	113	39	125	31	71	64	56	254	2,0
80	3"	BGM98111V	175	46	75	150	113	39	125	31	71	64	56	269	2,0
100	4"	BGM98114	195	52	94	150	113	39	125	31	71	64	56	289	2,0
125	5"	BGM98117	210	56	113	187	113	39	200	31	71	64	56	341	2,5
150	6"	BGM98117	225	56	126	187	113	39	200	31	71	64	56	356	2,5
200	8"	BGM98417	258	60	158	197	130	52	200	32	73	83	65	390	3,3
250	10"	BGM98422	288	68	191	197	130	52	200	32	73	83	65	420	3,3
300	12"	BGM98722	318	78	222	246	164	67	315	38	86	109	82	514	7,7

**Processklappe Serie KG6 bis KG9
 mit Grauguss Getriebe
 Butterfly valve series KG6 to KG9
 with cast iron gear operator
 DN 40 - DN 300**

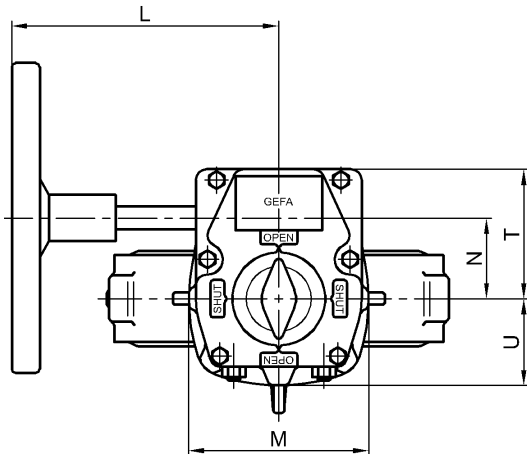
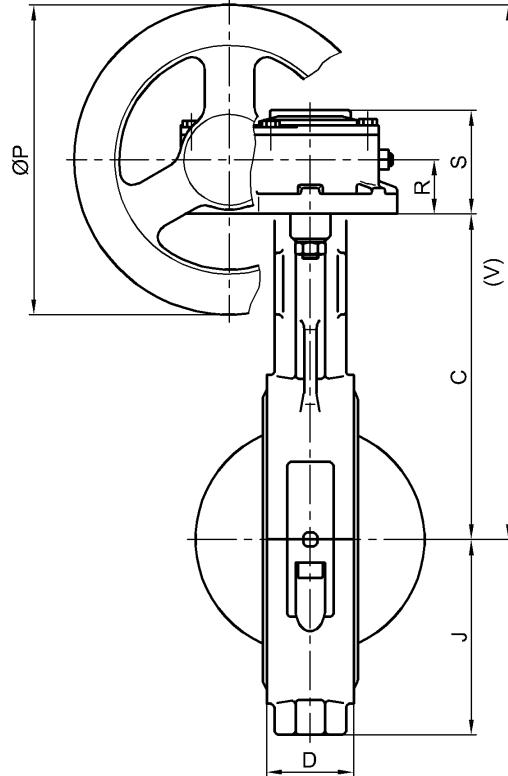
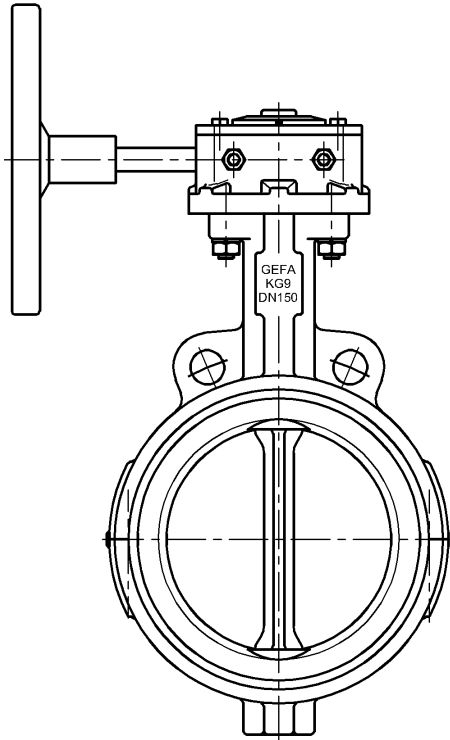

Getriebewerkstoffe / Gear materials
 Gehäuse / Body: Grauguss / cast iron
 Welle / Stem: Stahl / steel
 Handrad / Handwheel: Stahl / steel

Auf Wunsch ist ein Kettenrad lieferbar.
 Gewicht des Getriebes inklusive Handrad.
 Klappenspezifische Daten entnehmen Sie bitte den
 entsprechenden Datenblättern.

Upon request chain wheel can be supplied.
 Weight of gear operator including handwheel.
 Regarding valve data please refer to relevant data sheets.

DN	NPS	Getriebe Typ Gear type	C	D	J	L	M	N	ØP	R	S	T	U	V	kg
40 / 50	1 1/2" / 2"	BGMM0711V	130	43	60	150	88	39	125	27	58	62	45	220	2,9
65	2 1/2"	BGMM0711V	145	46	67	150	88	39	125	27	58	62	45	235	2,9
80	3"	BGMM0711V	160	46	75	150	88	39	125	27	58	62	45	250	2,9
100	4"	BGMM0714	180	52	94	150	88	39	125	27	58	62	45	270	2,9
125	5"	BGMM0717	195	56	113	187	88	39	200	27	58	62	45	322	3,5
150	6"	BGMM0717	210	56	126	187	88	39	200	27	58	62	45	337	3,5
200	8"	BGMM1017	240	60	158	197	116	52	200	35	67	84	58	375	5,0
250	10"	BGMM101022	270	68	191	197	116	52	200	35	67	84	58	405	5,0
300	12"	BGMM1222	300	78	222	301	150	67	250	42	81	105	75	467	10,0

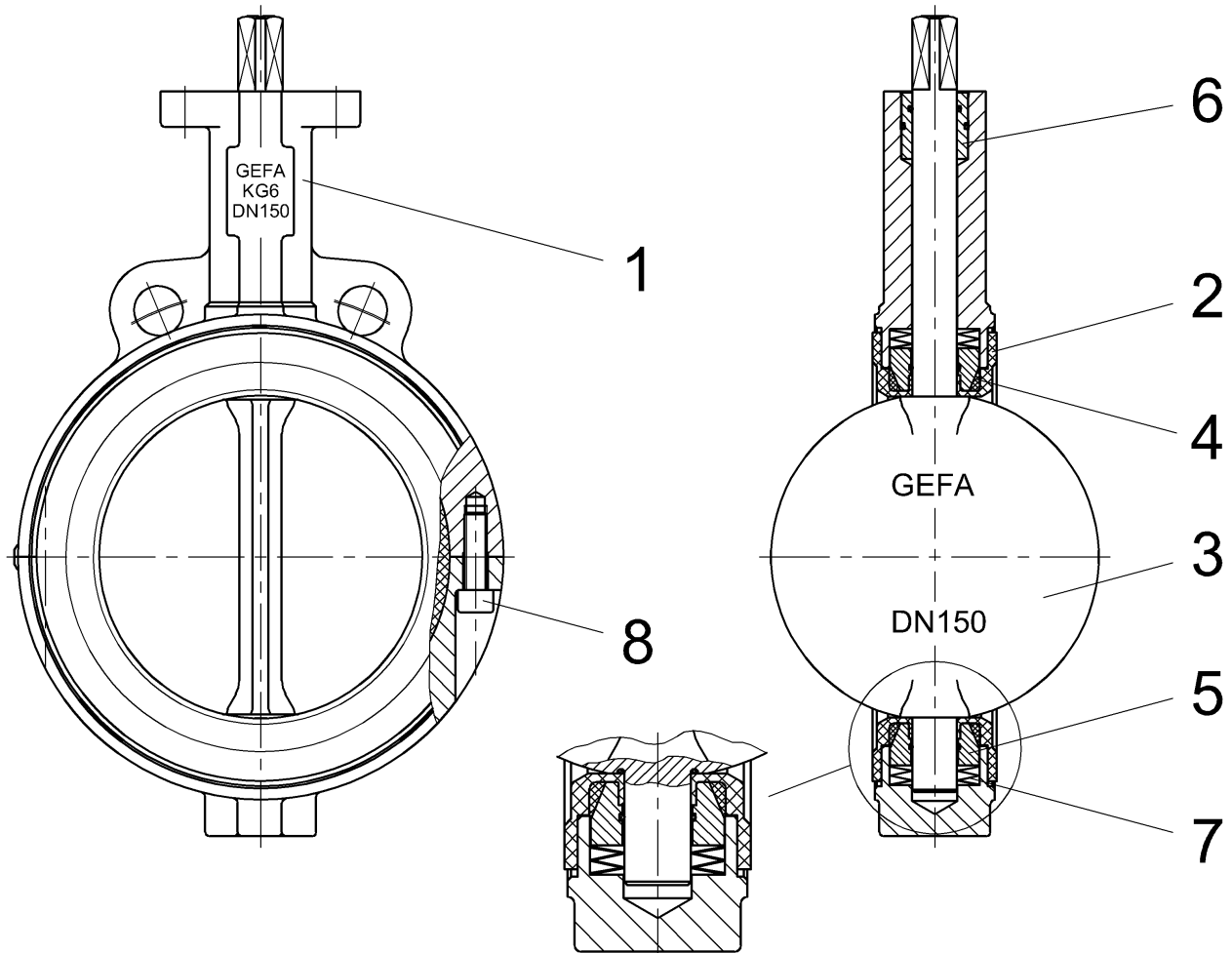

Teil Nr. Part No.	Bezeichnung Description	Material			
		KG6 2266 T	KG6 2277 T	KG6 2466 T	KG6 2477 T
1	Gehäuse Body	EN-GJL-250 Grauguss GG25 Cast iron GG25	EN-GJL-250 Grauguss GG25 Cast iron GG25	Sphäroguss Ductile iron	Sphäroguss Ductile iron
2*	Sitzring Seat	PTFE	PTFE	PTFE	PTFE
3	Klappenscheibe / Welle Disc / stem	≤ DN150: 1.4408/1.4408 ≥ DN200: 1.4408/1.4571	PTFE-beschichtet / 1.4462 PTFE-coated/1.4462	≤ DN150: 1.4408/1.4408 ≥ DN200: 1.4408/1.4571	PTFE-beschichtet / 1.4462 PTFE-coated /1.4462
4*	Elastomer	EPDM	EPDM	EPDM	EPDM
5	Druckstück Thrust pad	1.4305	1.4305	1.4305	1.4305
6*	Lagerbuchse mit O-Ring Bearing with O-ring	POM / NBR	POM / NBR	POM / NBR	POM / NBR
7	Feder Spring	Federstahl Spring steel	Federstahl Spring steel	Federstahl Spring steel	Federstahl Spring steel
8	Gehäuseschraube Body screw	DIN 912 – A2	DIN 912 – A2	DIN 912 – A2	DIN 912 – A2

* = Verschleißteile / Wearing parts

Wahlweise andere Werkstoffe lieferbar / Other materials available

Änderungen vorbehalten
 subject to changes

Introduction

The following information and instructions are important for perfect installation and safe operation of the valve. Prior to installation and initial use of the valve, the qualified staff in charge of installing and operating the valve has to be instructed according to this information.

Proper use

The PTFE-seated butterfly valve series K may only be used to stop, throttle and control media flows within the permissible pressure/temperature limits.

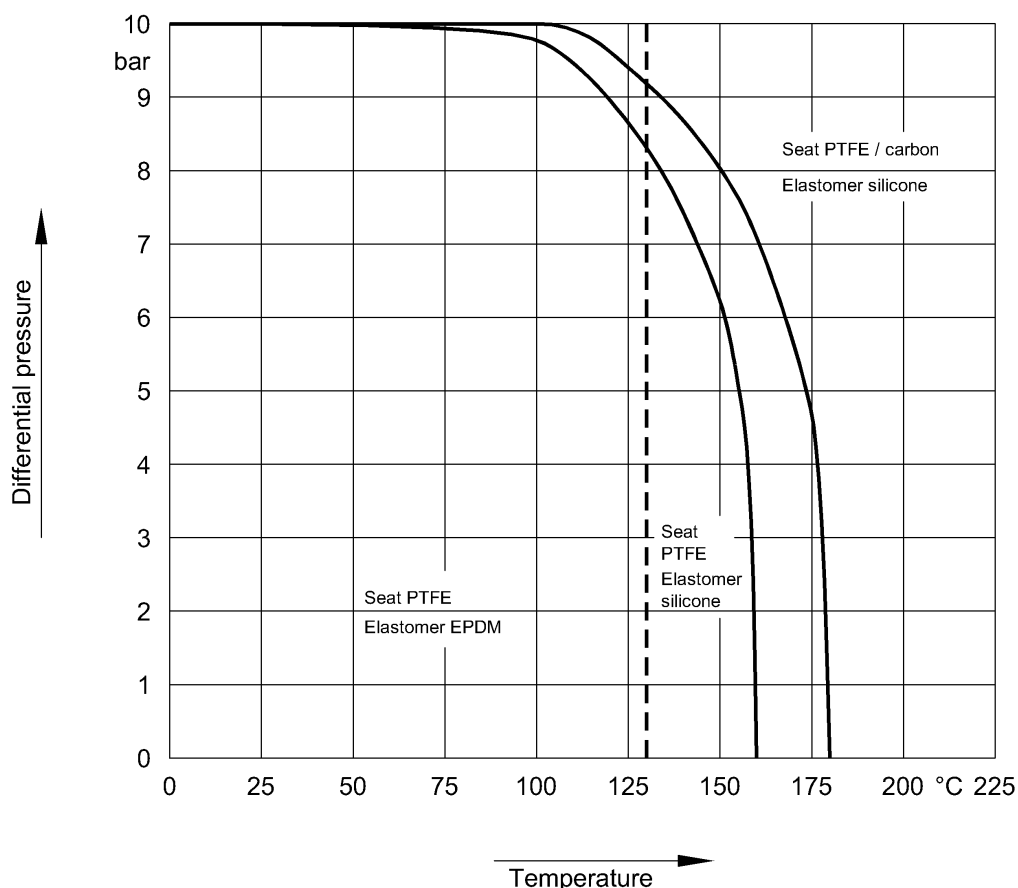

The suitability of the product-related parts used and their chemical resistance properties have to be clarified before start-up of the plant. The usual flow rate must not be exceeded. Vibrations, water hammers and cavitation as well as abrasive components result in damage of the valve and affect its service life.

Valves must not be used to support the pipeline nor as a step-up.

This includes the different kinds of operation like hand levers, gear operators, actuators, feedback and control systems.

When using a hand lever, handwheel and manual emergency operation, take care that there is enough space for a proper operation.

Earthing the valve

If the butterfly valve is supplied with anti-static device and used in potentially explosive zones, the earthing strap supplied with the valve must be connected effectively at site with the potential compensation cable before the valve is put into operation.

Transport and storage

The valve must be transported and stored dry and clean.
 In humid rooms, a drying material or heating must be used to avoid condensation.
 During transport and intermediate storage the butterfly valve should not be outside a temperature range of -15°C and $+30^{\circ}\text{C}$.
 The transport packaging protects the valve against soiling and damage. Impact and vibrations must be avoided.
 The outer paintwork (coating) must remain undamaged, otherwise the faulty spots must be repaired immediately.
 The factory-adjusted basic setting (position of the disc at delivery) must not be changed.

Conditions for mounting the valve

The PTFE-seated butterfly valve series K is installed between pipeline flanges acc. to DIN2501 or ANSI B16.5.
 The pipeline must not have any axial or angular offset, since otherwise the disc could be damaged and the PTFE-seat can become deformed, which is not permitted.

Due to the PTFE-seat design the butterfly valve is "self-sealing" to the flanges and does not require additional flange gaskets.

Pre-condition: The flange sealing surfaces have been checked to make sure that they have a smooth surface structure.

Residues (welding beads) must be removed.

No cross marks may be visible.

Use PTFE flange gaskets with metal back-up ring only in exceptional case.
 Make sure that the PTFE flange gaskets cover the whole sealing surface of the flange connection.

The "clearance" of the mating flanges - including inner coating - has to be sufficient to allow the disc to be fully opened without touching ($\text{ØDi} \geq \text{ØL} + 6 \text{ mm}$).

This must be checked before the valve is installed and compared with the space necessary for the valve according to the table.

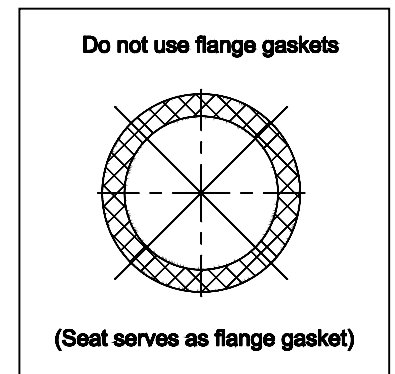

DN	D	ØL	X
50	43	33	6
65	46	48	10
80	46	64	17
100	52	91	27
125	56	117	37
150	56	137	46
200	60	190	70
250	68	240	91
300	78	290	111
350	78	330	131
400	102	377	144
500	127	475	182

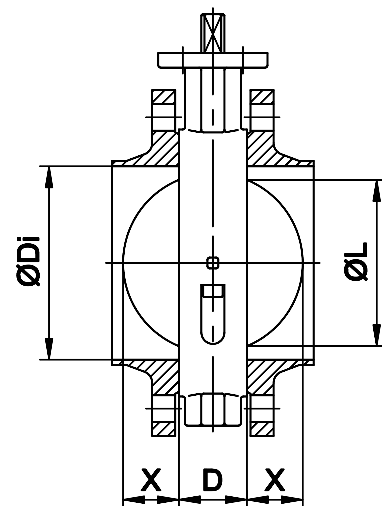

Transport packaging

Transport packaging protects the interior of the valve from soiling and damage.
 Do not remove the packaging until the valve is going to be installed.

Installation position

Basically the butterfly valve series K can be installed in any position.
 The recommended position, however, is with the shaft being horizontal.
 The lower disc edge should open in flow direction.

Installation

The PTFE-seated butterfly valve series K has to be switched to the fully closed position or a slightly angled position.

The position of the disc must be within the face-to-face dimension of the valve.

Spread the mating flanges and insert the valve carefully between the flanges.

If the pipeline is to be welded at site, temporary fitting blocks should be installed instead of the butterfly valve, since flying sparks and welding residues can damage the valve seat due to high temperatures. Never leave the butterfly valve installed when welding of the pipeline/flanges has to be completed.

Center the butterfly valve using the flange screws. The outside diameter of the valve body is used for full centering!

Remove the flange-spreaders and tighten the flange screws slightly and evenly crosswise with the disc fully closed.

During this procedure, check that the valve is centered between the mating flanges.

Open and close the valve several times and cross-tighten the flange screws once again with the disc in closed position. (Tightening torque: please refer to below table).

Check that the disc has adequate clearance.

When installing the lug type butterfly valve as end-in-line valve, the free port must be secured by a blind flange.

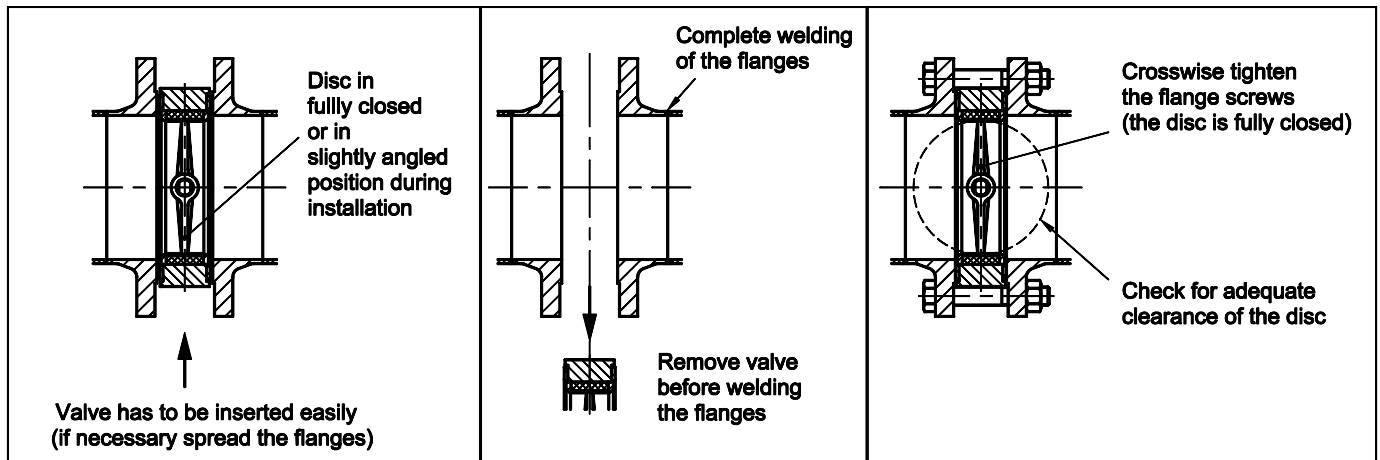

Tightening torque for flange screws

DN	40	50	65	80	100	125	150	200	250	300	350	400	500
NPS	1 ½"	2"	2 ½"	3"	4"	5"	6"	8"	10"	12"	14"	16"	20"
Tightening torque [Nm]	30	30	35	35	40	55	80	100	100	120	130	170	170

Mounting of actuators

It must be ensured that the actuator is centred on the valve shaft.
The weight of a mounted actuator must not place a one-sided load on the shaft of the valve:
if necessary actuators must be supported without fixing.
External loads must not be applied to actuators, this can damage or destroy the valve.

Initial operation

The butterfly valve has been tested for leakage using air or water. Residues of the test medium may still be on the contact surfaces of the valve. Possible reactions with the operating medium must be observed.
Prior to initial operation, the pipeline must be flushed effectively with the valve fully opened to eliminate soiling and to avoid damage to the sealing surfaces. The valve must not be switched during the flushing process.

During a system pressure test the following pressures must not be exceeded:

1,5 x PN with disc in open position
1,1 x PN with disc in closed position

Impermissible operation

Never operate the butterfly valve without actuating devices and/or locking of the shaft.
Do not operate the valve in the cavitation area.
Do not exceed the pressure/temperature range.
Avoid all foreign particles on the sealing surfaces.

Removing the valve

Before removing the butterfly valve make sure that the pipe section is depressurised and evacuated.
In case of toxic, caustic and other outgasing media the pipe section must also be ventilated.
Safety classification is the responsibility of the system operator.

The butterfly valve is removed by loosening the flange screws and sufficient spreading of the mating flanges.

The valve disc must be closed at an angle within the face-to-face dimension of the valve to prevent damage to the disc. Actuators either have to be dismantled before the valve is removed or they have to be secured against unauthorized or unintentional operation.

Disposal / repair of the valve

After having removed the valve it has to be disassembled and cleaned to prevent injuries caused by residues of the medium.
If the valve is returned to the manufacturer, a safety data sheet relating to the media must be included.

Subject to modifications without notice.

Edition: 2010-07-13

Maintenance

- The valves do not require any special maintenance.

Disassembly

- Valves with hand lever:
Loosen the lateral screw joint of the hand lever and pull the hand lever off the valve stem (3).
If only the seat (2) or the disc (3) have to be replaced, the throttle plate can be left mounted.
Remove the throttle plate by loosening the screws to replace the bearing (6).
- Valves with actuator:
Loosen the fastening screws between the MULTITOP mounting plate (29) and the actuator or between the valve and the bracket and remove the actuator to replace the bearing (6).
Remove the MULTITOP mounting plate (29) from the valve by loosening the fastening screws (31) and the clamping sleeves (30).
If only the seat (2) or the disc (3) has to be replaced, the actuator may remain on the valve.
- Turn the disc to "OPEN" position.
- Loosen and remove the two body screws (8).
- Pull off the lower part of the body (1b). The lower part or the body can easily be pulled off by pressing screw drivers into the body split.
- Pull the disc (3) with the seat (2) out of the upper part of the body (1a).
- If the disc (3) is to be reused, it should be heated together with the seat (2) to at least 100 °C (better 150 °C). This can be achieved in a water bath (boiling, 100°C) or better in a heating furnace.
After warming the disc / seat unit, the seat ring becomes pliable. Deform the seat into an oval and pull it first over the lower stem part of the disc. Thereafter, pull the seat upwards.
- Allocate the thrust pads (5), disc spring washers or compression springs (7) and the adjusting washers (if present) to the upper and lower body part (1a/1b) in the same way as they were found.
Comment: Four disc spring washers are used per body half for DN 50 to DN 150 and DN 500.
One compression spring is used per body half for DN 200 to DN 400.
- Check all part for flawless condition and renew them, if required. Only use original GEFA spare parts.

Assembly

- Thoroughly clean all parts and check them for wear. Parts that show wear or corrosion must be replaced to ensure operational safety in future.
- Equip the thrust pads (5) with a new FPM O-ring (10), if required.
- Allocate the disc spring washers or compression springs (7) to the body halves (exchange them, when they are corroded). Insert the adjusting washers into the body parts in the original pattern.
- Check the disc (3) and slide a new FEP O-ring over both stem parts and into the groove of the disc.
- Heat the seat (2) in the form it is delivered as spare part with inlayed elastomer (4) in an heating furnace to 150°C (maximum 15 minutes) or in boiling water to 100°C.
- Pull the hot seat (2) over the long stem part of the prepared disc (3). Clamp the flat of the disc with a vice (use aluminium jaws).
Pull the seat over the short stem part. For this purpose, the seat is distorted into an oval.
- Place the disc spring washers or compression spring (7) and the thrust pad (5) into the upper part of the body (1a).
- Insert the complete disc (3) / seat (2) unit into the upper part of the body (1a).
- Place the disc spring washers or compression spring (7) and the thrust pad (5) into the lower part of the body (1b).
- Assemble the upper and lower part of the body (1a/1b) and fasten them with the body screws (8).
Each body half has a small moulded cam at the body split that shows the correct position of the body halves in relation to each other.
- Insert the bearing with the O-rings (6) into the upper body part (1a) if the bearing has to be replaced.
- After the assembly the disc has to be switched for several times (at least 4x) by 180°.
- Check the seat and the stem tightness. Test pressure 1.1 times nominal pressure.
- Valves with hand lever:
Loosely attach the throttle plate with the screws to the top flange. Slide the hand lever onto the stem and position the throttle plate. Tighten the fastening screws of the throttle plate and attach the lever with the lateral screw joint.
- Valves with actuator:
Attach the whole actuator unit, align it and fasten it with screws.

Mounting of the MULTITOP mounting plate.

- Position the mounting plate (29) on the body.
- Insert the spring dowel sleeves (30) through the mounting plate into the body. The slot in the spring dowel sleeve must point in the force direction (see arrow in the assembly drawing) to achieve a rigid connection. Do not insert the mounting plate without using spring dowel sleeves, as the transverse forces cannot be absorbed by the screws.
- Insert the cylinder screws (31) and tighten them.
- Slide a square adapter (32) onto the stem, if required. Prevent the square adapter from sliding down the stem by using the attached washer (33), if required.

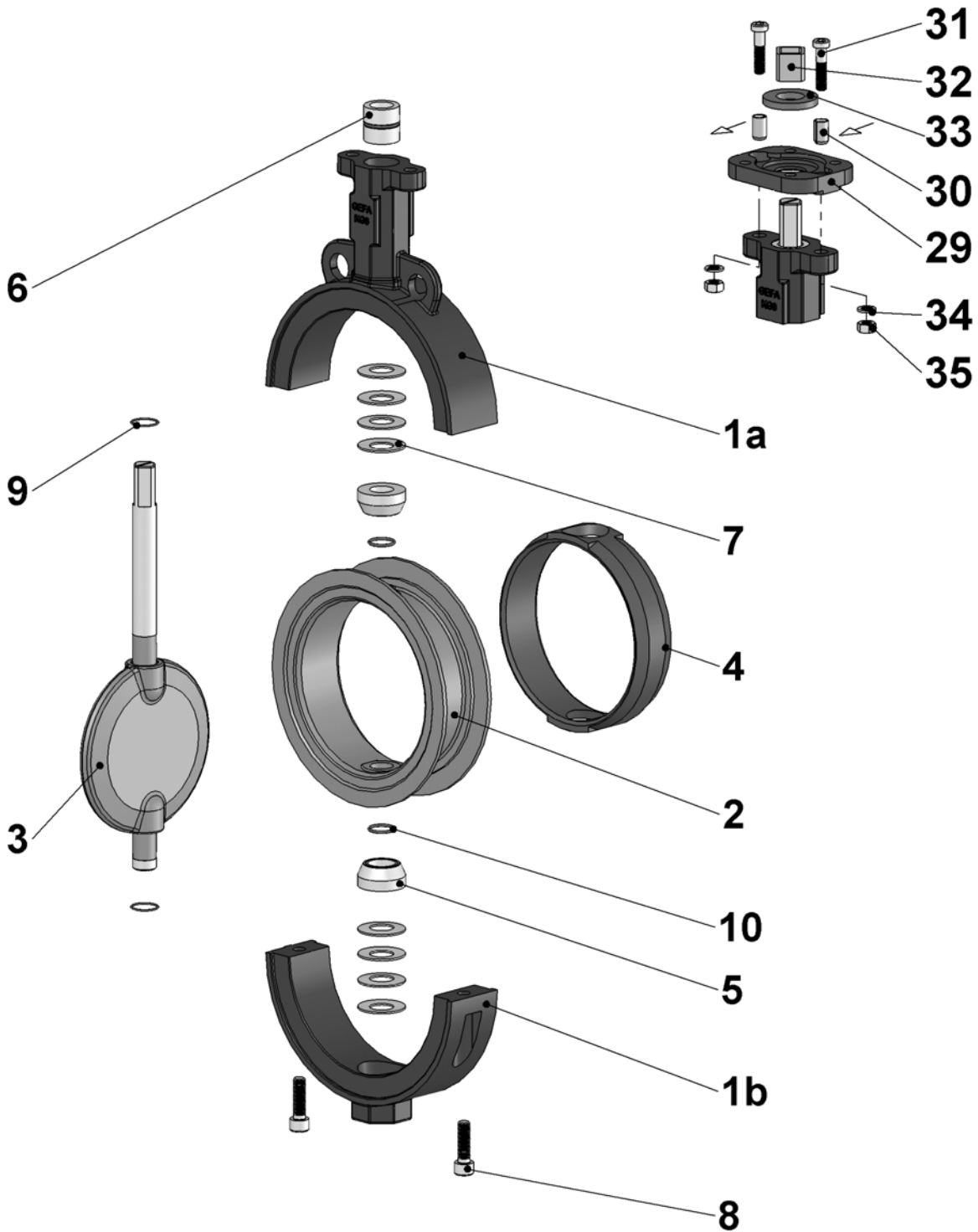

- | | | | | | |
|----|------------------------|----|---------------------------------------|----|---------------------|
| 1a | Upper part of the body | 6 | Bearing with O-ring | 30 | Spring dowel sleeve |
| 1b | Lower part of the body | 7 | Disc spring washer/compression spring | 31 | Cylinder screw |
| 2 | Seat | 8 | Body screw | 32 | Square adapter |
| 3 | Disc | 9 | O-ring | 33 | Retaining washer |
| 4 | Elastomer | 10 | O-ring | 34 | Spring washer |
| 5 | Thrust pad | 29 | MULTITOP mounting plate | 35 | Hexagonal nut |