



**Continental Disc®  
Corporation**

## **Preparation and Installation of the Standard Type Rupture Disc (Light Lip and Heavy Lip) in 30° Seat 7I Insert, Full-Bolted, and Union Type Holders**

### **WARNING**

USER SHOULD READ AND THOROUGHLY UNDERSTAND THESE INSTRUCTIONS BEFORE INSTALLING RUPTURE DISC. THESE INSTRUCTIONS DO NOT PURPORT TO ADDRESS ALL OF THE SAFETY FACTORS ASSOCIATED WITH THE RUPTURE DISC'S USE IN SERVICE. IT IS THE RESPONSIBILITY OF THE USER TO ESTABLISH APPROPRIATE SAFETY, HEALTH, AND TRAINING MEASURES FOR THEIR PERSONNEL INSTALLING, SERVICING, OR WORKING IN AN AREA WHERE RUPTURE DISC ASSEMBLIES ARE IN USE. SERVICE AND/OR MAINTENANCE ON OR AROUND THE RUPTURE DISC DEVICE MUST NOT BE PERFORMED WHILE THE DEVICE IS SUBJECTED TO OPERATING PRESSURES AND/OR TEMPERATURES.

IT IS THE USER'S SOLE RESPONSIBILITY FOR DESIGN AND PLACEMENT OF RUPTURE DISCS WITHIN THEIR FACILITY AND UPON THE EQUIPMENT UPON WHICH THE RUPTURE DISC OF USER'S SELECTION IS TO BE LOCATED. IT IS USER'S SOLE RESPONSIBILITY FOR THE DESIGN OF ADEQUATE VENTING AND INSTALLATION OF ADEQUATE VENT PIPING OR DIRECTIONAL FLOW AFTER RUPTURE OCCURS WITH THE RUPTURE DISC AS INTENDED. WHEN SIZE IS SPECIFIED, CONTINENTAL DISC CORPORATION ASSUMES THAT ADEQUATE PROVISIONS HAVE BEEN MADE BY PURCHASER FOR PROPER VENTING OF A SYSTEM TO RELIEVE THE SPECIFIC PRESSURE. LOCATE RUPTURE DISC WHERE PEOPLE OR PROPERTY WILL NOT BE EXPOSED TO THE SYSTEM DISCHARGE IN CASE OF RUPTURE. VENT TOXIC OR FLAMMABLE FUMES OR LIQUIDS TO A SAFE LOCATION TO PREVENT PERSONAL INJURY OR PROPERTY DAMAGE.

IT IS THE USER'S SOLE RESPONSIBILITY TO SPECIFY THE BURST PRESSURE RATING OF A RUPTURE DISC AT A COINCIDENT TEMPERATURE AT WHICH THE RUPTURE DISC IS TO BE USED. A RUPTURE DISC IS A TEMPERATURE SENSITIVE DEVICE. THE BURST PRESSURE OF THE RUPTURE DISC IS DIRECTLY AFFECTED BY ITS EXPOSURE TO THE COINCIDENT TEMPERATURE. GENERALLY, AS THE TEMPERATURE AT THE RUPTURE DISC INCREASES, THE BURST PRESSURE DECREASES; INVERSELY, AS THE TEMPERATURE AT THE RUPTURE DISC DECREASES, THE BURST PRESSURE MAY INCREASE. FAILURE TO PROPERLY UTILIZE A RUPTURE DISC AT THE SPECIFIED COINCIDENT TEMPERATURE COULD CAUSE PREMATURE FAILURE OR OVERPRESSURIZATION OF A SYSTEM.

THE INSTANTANEOUS RELEASE OF PRESSURE FROM THE RUPTURE DISC CAN CREATE VIOLENT NOISES DUE TO THE DISCHARGE AT SONIC VELOCITY. IT IS THE USER'S SOLE RESPONSIBILITY TO PROTECT AGAINST HEARING DAMAGE TO ANY BYSTANDERS.

RUPTURE DISCS AND TAGS ARE MADE OF METAL FOILS OF VARYING THICKNESS. THE METAL EDGES MAY BE SHARP. PERSONNEL INSTALLING OR EXAMINING THE RUPTURE DISCS SHOULD PROTECT AGAINST CUTS OR INJURY WHEN HANDLING THE RUPTURE DISC. DO NOT LIFT A RUPTURE DISC BY ITS ATTACHED TAG.

PARTICLES MAY BE DISCHARGED WHEN THE RUPTURE DISC RUPTURES. THESE PARTICLES MAY BE PART OF THE RUPTURE DISC ITSELF, OR OTHER ENVIRONMENTAL MATTER IN THE SYSTEM. IT IS THE USER'S SOLE RESPONSIBILITY TO ASSURE THAT THESE PARTICLES ARE DIRECTED TO A SAFE AREA TO PREVENT PERSONAL INJURY OR PROPERTY DAMAGE.

THERE IS NO GUARANTEE OF RUPTURE DISC LIFE. SUCH LIFE SPAN IS AFFECTED BY CORROSION, CREEP AND FATIGUE, AND PHYSICAL DAMAGE. THESE CONDITIONS WILL DERATE THE RUPTURE DISC TO A LOWER SET PRESSURE. THE CUSTOMER AND/OR USER SHOULD BE PREPARED TO HANDLE PREMATURE FAILURE OF THE RUPTURE DISC. THE MEDIA OR OTHER ENVIRONMENTAL CONDITIONS SHOULD NOT ALLOW ANY BUILDUP OR SOLIDIFICATION OF MEDIA TO OCCUR ON A RUPTURE DISC. THIS MAY INCREASE THE PRESSURE SETTING OF THE RUPTURE DISC.

CUSTOMER AND/OR ITS INSTALLER SHALL BE SOLELY RESPONSIBLE FOR THE PROPER INSTALLATION OF SELLER'S HOLDERS AND RUPTURE DISCS INTO A SYSTEM. CUSTOMER AND/OR ITS INSTALLER SHALL BE SOLELY RESPONSIBLE FOR IMPROPER INSTALLATION AND PHYSICAL DAMAGE RESULTING THEREFROM, INCLUDING BUT NOT LIMITED TO, DAMAGE RESULTING FROM LEAKAGE, IMPROPER TORQUING OR SEATING OF A RUPTURE DISC OR FAILURE TO FOLLOW INSTALLATION INSTRUCTIONS WHERE PROVIDED.

RUPTURE DISCS ARE PRECISION SAFETY DEVICES AND MUST BE INSTALLED PROPERLY. RUPTURE DISCS MUST BE INSTALLED BY TRAINED, KNOWLEDGEABLE INSTALLERS AND ONLY WITHIN ENVIRONMENTS SUITABLE AND APPROPRIATE FOR A RUPTURE DISC. CARE MUST BE USED IN A FACILITY'S DESIGN TO PROTECT BOTH THE RUPTURE DISC FROM INADVERTENT DAMAGE WHICH COULD CAUSE ITS PREMATURE RELEASE AND TO PROTECT INDIVIDUALS EXPOSED TO HAZARDS CREATED BY SUCH SUDDEN RELEASE.

PROPER INSTALLATION OF A RUPTURE DISC IS CRITICAL TO PERFORMANCE AND TO SAFETY. FAILURE TO PROVIDE PROPER SEATING OF A RUPTURE DISC MAY AFFECT RUPTURE DISC PERFORMANCE, BURST PRESSURE ACCURACY AND MAY RESULT IN ITS PREMATURE FAILURE.

## I. Safety Precautions Before Installation

1. The STANDARD Type rupture disc is a precision instrument and must be handled with extreme care. Rupture discs should be installed only by qualified personnel familiar with rupture discs and proper piping practices.
2. Do not install rupture disc if there is any damage in the dome area. A damaged rupture disc is any rupture disc with visible nicks or dents in the dome.
3. Continental Disc Corporation does not recommend reinstalling a rupture disc that has been removed from the holder as reinstallation may adversely affect the joint sealing capabilities and/or performance of the rupture disc.
4. See rupture disc tag to verify set pressure, operating temperature, and all other operating parameters.

## II. 7I Insert Type 30° Seat Holder

### A. Preparation of Holders for Installation

#### New Installation

Clean all foreign material from the rupture disc sealing area of both the holder inlet and outlet.

#### Replacement Installation

1. If the Burst Disc Indicator (B.D.I.<sup>®</sup>) Alarm System is used, disconnect the alarm strip from the monitor by unplugging the B.D.I. connector from the lead wire connector.
2. Remove the holder from the system and place on a flat surface.
3. Disassemble the holder by loosening the pre-assembly screws, or by removing the pre-assembly cap screws, whichever is applicable. Lift the holder outlet up and set aside; then remove the burst rupture disc.
4. Clean the rupture disc sealing area of both the holder inlet and outlet. These surfaces must be completely clean and free of all rust, corrosion, and foreign material to ensure a proper seal. Use of solvents, steel wool, or fine emery cloth is permissible. Do not re-machine. Do not use scraper or abrasives.
5. Inspect the rupture disc sealing area for nicks, scratches, or pitting. If any of these conditions are present, consult the factory for repair.
6. Remove any adhered gasket material from previous installation.

### B. Assembly of the Rupture Disc and Holder (See Figure A)

Component parts of the 7I Insert 30° Seat Holder assembly are illustrated in the proper installation sequence.

1. Carefully remove and discard any shipping protectors furnished with rupture discs or holder. **DO NOT INSTALL A SHIPPING PROTECTOR IN A HOLDER ASSEMBLY.**
2. Place the holder inlet on a flat surface.
3. Place the STANDARD Type rupture disc on the holder inlet opening with the dome side facing up as illustrated.
4. If the 30° Seat B.D.I. Alarm System is used, visually inspect the adhesion of the strip to the Teflon<sup>®</sup> seal and the electrical circuit. If the strip has become detached or the circuit has been broken, **DO NOT INSTALL THE RUPTURE DISC.** Ensure that the B.D.I. connector strip extends straight and flat.
5. Align and lower the holder outlet carefully onto the holder inlet.
6. Fasten the assembly together by tightening the pre-assembly screws or by replacing and tightening the pre-assembly cap screws.

\*Teflon is a registered trademark of E.I. du Pont de Nemours and Company used under license.

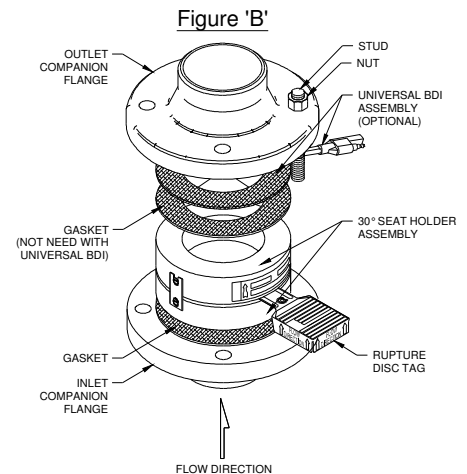
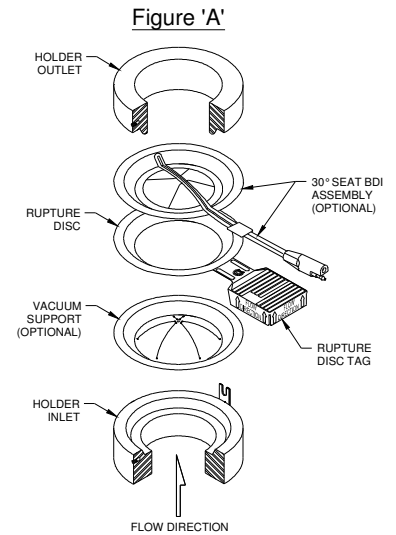

## C. Installation of the 7I Insert Type 30° Seat Holder Assembly Into the System (See Figure B)

1. If the B.D.I. Alarm System is to be used, refer to the Universal B.D.I. Assembly Installation Instructions for additional details. (Note: The Universal B.D.I. assembly and the 30° seat B.D.I. assembly are optional accessories, and it is not necessary to use the two together at any one time.)
2. Before placing the assembly into the system, ensure that the companion flange gasket surfaces are clean and free of all rust, corrosion, and foreign material.
3. A J-Hook (optional) may be provided in the holder inlet to ensure correct installation of the assembly relative to flow direction. If the J-Hook is used, the corresponding inlet companion flange must be drilled to accommodate the J-Hook prior to installation of the assembly. Refer to the J-Hook Installation Guide for locating and drilling specifications. NOTE: If replacing another manufacturer's holder, the corresponding inlet companion flange must be re-drilled to accommodate the J-hook in the Continental Disc holder inlet.
4. Install the 7I Insert Type 30° Seat Holder assembly and customer furnished gaskets **WITH ALL FLOW ARROWS POINTING IN THE PROPER FLOW DIRECTION** and the J-Hook (if furnished) inserted into the drilled companion flange.
5. If the B.D.I. Alarm System is used, installation of the strain relief device is necessary (see Figure C).

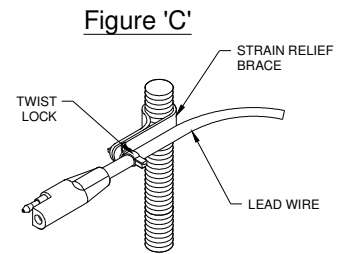

Slip the strain relief device over one companion flange stud as shown. Place the device near where the B.D.I. strip exits.

Allowing sufficient slack for easy connection to the B.D.I. connector, secure the lead wire to the strain relief device by fastening the twistlock on the clip.

6. Install lightly oiled, free running studs and nuts to finger tightness. Using a cross torquing pattern (see Figure D), torque each nut with a calibrated torque wrench at 20% increments of recommended torque value (see Table 1). Repeat 20% increments and cross torquing pattern until final torque value is achieved. Recheck all nuts in rotational sequence at final torque value. When properly torqued, the distance between the holder inlet and the holder outlet should be approximately equal around the perimeter of the holder. These values are based on using gasket materials having a gasket factor of 2.75, gasket seating stress of 3,700 psi, and stud and nut material per ASME SA193-B7 and SA194-2H respectively, with a stress of up to 25,000 psi. The use of studs and nuts with lower strength may prove unsatisfactory.

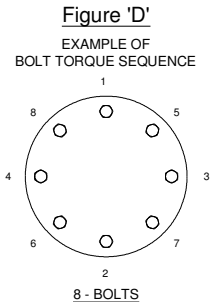

7. If the B.D.I. Alarm System is used, plug the B.D.I. connector into the lead wire connector using a slight twisting action.

## III. Full-Bolted Type 30° Seat Holder

### A. Preparation of Holders for Installation

#### New Installation

Clean all foreign material from the rupture disc sealing area of both the holder inlet and outlet.

#### Replacement Installation

1. If the Burst Disc Indicator (B.D.I.®) Alarm System is used, disconnect the alarm strip from the monitor by unplugging the B.D.I. connector from the lead wire connector.
2. Remove the studs and nuts that hold the assembly together.
3. Separate the inlet and outlet; then remove the burst rupture disc.
4. Clean the rupture disc sealing area of both the holder inlet and outlet. These surfaces must be completely clean and free of all rust, corrosion, and foreign material to ensure a proper seal. Use of solvents, steel wool, or fine emery cloth is permissible. Do not re-machine. Do not use scraper or abrasives.
5. Inspect the rupture disc sealing area for nicks, scratches, or pitting. If any of these conditions are present, consult the factory for repair.
6. Remove any adhered gasket material from previous installation.

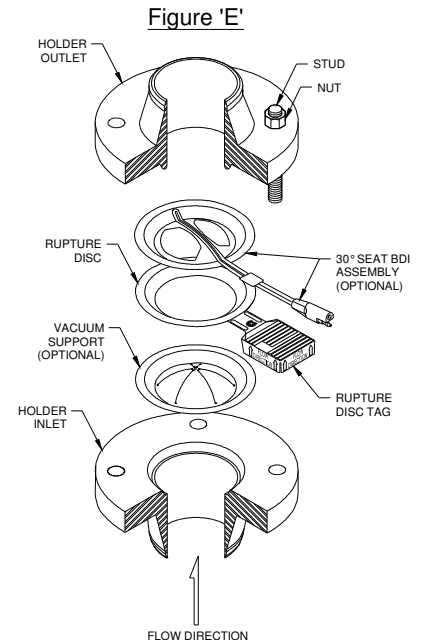

## B. Assembly of the Rupture Disc and Holder (See Figure E)

Component parts of the Full-Bolted Type 30° Seat Holder assembly are illustrated in the proper installation sequence.

1. Carefully remove and discard any shipping protectors furnished with rupture discs or holder. **DO NOT INSTALL A SHIPPING PROTECTOR IN A HOLDER ASSEMBLY.**
2. Place the STANDARD Type rupture disc on the holder inlet opening with the dome side facing up as illustrated.
3. If the 30° Seat B.D.I. Alarm System is used, visually inspect the adhesion of the strip to the Teflon® seal and the electrical circuit. If the strip has become detached or the circuit has been broken, **DO NOT INSTALL THE RUPTURE DISC.** Ensure that the B.D.I. connector strip extends straight and flat.
4. Align and lower the holder outlet carefully onto the holder inlet.
5. If the 30° Seat B.D.I. Alarm System is used, installation of the strain relief device is necessary. This requires that one stud approximately 2 inches longer than the others is needed near where the B.D.I. strip exits (see Figure F). Slip the strain relief device over the longer stud and secure with a nut. Allowing sufficient slack for easy connection to the B.D.I. connector, secure the lead wire to the strain relief device by fastening the twist lock.
6. Install lightly oiled, free running studs and nuts to finger tightness. Using a cross torquing pattern (see Figure D, page 3), torque each nut with a calibrated torque wrench at 20% increments of recommended torque value (see Table 1). Repeat 20% increments and cross torquing pattern until final torque value is achieved. Recheck all nuts in rotational sequence at final torque value. When properly torqued, the distance between the holder inlet and the holder outlet should be approximately equal around the perimeter of the holder. These values are based on using gasket materials having a gasket factor of 2.75, gasket seating stress of 3,700 psi, and stud and nut material per ASME SA193-B7 and SA194-2H respectively, with a stress of up to 25,000 psi. The use of studs and nuts with lower strength may prove unsatisfactory.
7. If the 30° Seat B.D.I. Alarm System is used, plug the B.D.I. connector into the lead wire connector using a slight twisting action.

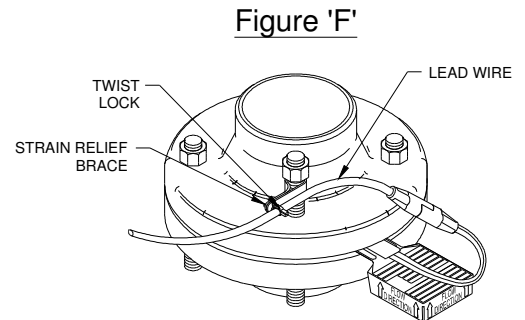

## IV. Union Type Holder

### A. Preparation of Holders for Installation

#### New and Replacement Installation

1. Clean the rupture disc sealing area of both the holder inlet and outlet. These surfaces must be completely clean and free of all rust, corrosion, and foreign material to ensure a proper seal. Use of solvents, steel wool, or fine emery cloth is permissible. Do not re-machine. Do not use scraper or abrasives.
2. Care should be taken during assembly and installation to ensure that nothing sharp protrudes down through the inlet or outlet cavities. A rupture disc that has been scratched, dented, or damaged in any way, may result in premature failure.

### B. Assembly of the Rupture Disc and Holder (See Figure G)

Component parts of the Union Type assembly are illustrated in the proper installation sequence.

1. Place the holder inlet on a flat surface.
2. Position the rupture disc in the holder inlet with the dome side facing up as shown. Handle with care.
3. Carefully lower the holder outlet onto the rupture disc.

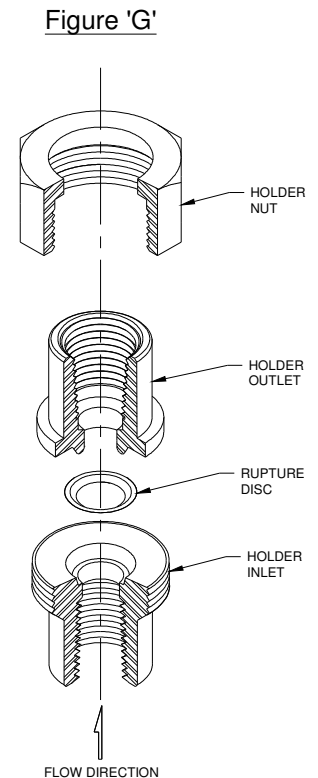

4. Slip the nut over the holder outlet and thread it onto the holder inlet. Place a wrench on the holder inlet to keep it from turning. Using a calibrated torque wrench, torque the nut to the following requirements:

Torque for all Discs except Aluminum w/Teflon Liners				Torque for Aluminum Discs w/Teflon Liners				
Size	Pressure Rating	Torque Requirement		Size	Disc	Holder	Torque Requirement	
	Holder	(Ft•Lbs)	(N•m)				(Ft•Lbs)	(N•m)
1/2"	3000	50	68	1/2"	ALL	3000	50	68
	6000	80	108		ALL	6000	80	108
1"	4000	200	271	1"	ALL	4000	150	203
	6000	300	407		ALL	6000	150	203
1-1/2"	4000	800	1085	1-1/2"	ALL	4000	200	271
2"	4000	2000	2711	2"	≤ 300	4000	350	475
					> 300 - 500	4000	1300	1762

Recommended Torque Values for Standard Type Rupture Discs  
(Light Lip and Heavy Lip)

TABLE 1

SIZE		COMPANION FLANGE RATING			DISCS WITHOUT 30° SEAT B.D.I. ASSEMBLY		DISCS WITH 30° SEAT B.D.I. ASSEMBLY OR TEFLON LINERS	
IN	MM	ANSI	DIN	JIS	TORQUE (FT•LB)	TORQUE (N•m)	TORQUE (FT•LB)	TORQUE (N•m)
1/2"	12	150	---	---	10	14	7	10
1/2"	12	---	10/16	---	10	14	6	8
1/2"	12	---	---	10/16/20	10	14	6	8
1/2"	12	300/600	---	---	14	19	7	10
1/2"	12	---	25/40	---	10	14	6	8
1/2"	12	---	---	30/40	18	24	8	11
1/2"	12	900/1500	---	---	51	69	---	---
1/2"	12	2500	---	---	84	114	---	---
3/4"	20	150	---	---	10	14	---	---
3/4"	20	---	10/16	10/16/20	10	14	---	---
3/4"	20	300/600	---	---	23	31	---	---
3/4"	20	---	25/40	---	12	16	---	---
3/4"	20	---	---	30/40	25	34	---	---
3/4"	20	900/1500	---	---	70	95	---	---
3/4"	20	2500	---	---	116	157	---	---
1	25	150	---	---	20	28	9	12
1	25	---	10/16	---	19	26	9	12
1	25	---	---	10/16/20	25	34	12	16
1	25	300/600	---	---	30	41	12	16
1	25	---	25/40	---	23	32	9	12
1	25	---	---	30/40	30	41	12	16
1	25	900/1500	---	---	110	150	---	---
1	25	2500	---	---	180	244	---	---
1-1/2	40	150	---	---	30	41	13	18
1-1/2	40	---	10/16	10/16/20	38	52	17	23
1-1/2	40	300/600	---	---	50	68	20	27
1-1/2	40	---	25/40	---	42	57	17	23
1-1/2	40	---	---	30/40	53	72	21	28
1-1/2	40	900/1500	---	---	165	224	---	---
1-1/2	40	2500	---	---	375	509	---	---
2	50	150	10/16	10	40	55	21	28
2	50	---	---	16/20	20	27	11	15
2	50	300/600	---	---	45	61	39	53
2	50	---	25/40	---	91	124	79	107
2	50	---	---	30/40	45	61	39	53
2	50	900/1500	---	---	130	177	---	---
2	50	2500	---	---	250	339	---	---
3	80	150	---	---	50	68	20	27
3	80	---	10/16	10	25	34	10	14
3	80	---	---	16/20	31	42	13	18
3	80	300/600	---	---	85	115	20	27
3	80	---	25/40	---	71	96	17	23
3	80	---	---	30/40	89	121	21	28
3	80	900	---	---	145	197	---	---
3	80	1500	---	---	325	441	---	---
3	80	2500	---	---	485	658	---	---

Recommended Torque Values for Standard Type Rupture Discs  
(Light Lip and Heavy Lip)

TABLE 1

SIZE		COMPANION FLANGE RATING			DISCS WITHOUT 30° SEAT B.D.I. ASSEMBLY		DISCS WITH 30° SEAT B.D.I. ASSEMBLY OR TEFLON LINERS	
IN	MM	ANSI	DIN	JIS	TORQUE (FT•LB)	TORQUE (N•m)	TORQUE (FT•LB)	TORQUE (N•m)
4	100	150	10/16	10	50	68	15	20
4	100	---	---	16/20	63	86	19	26
4	100	300	---	---	70	95	25	34
4	100	---	25/40	---	73	99	26	35
4	100	---	---	30	81	110	29	39
4	100	600	---	---	160	217	---	---
4	100	---	---	40	158	214	---	---
4	100	900	---	---	310	421	---	---
4	100	1500	---	---	480	651	---	---
4	100	2500	---	---	875	1186	---	---
6	150	150	---	---	60	82	20	27
6	150	---	10/16	10	63	86	21	28
6	150	---	---	16/20	46	62	15	20
6	150	300	---	---	100	136	20	27
6	150	---	25/40	---	189	256	38	52
6	150	---	---	30	126	171	25	34
6	150	600	---	---	255	346	---	---
6	150	---	---	40	241	327	---	---
8	200	150	---	---	110	149	50	68
8	200	---	10	---	115	156	52	70
8	200	---	16	10	77	104	35	47
8	200	---	---	16/20	85	115	38	52
8	200	300	---	---	185	251	40	54
8	200	---	25	30	200	271	43	58
8	200	---	40	---	225	305	49	66
8	200	600	---	---	375	508	---	---
8	200	---	---	40	315	427	---	---
10	250	150	---	---	153	207	60	81
10	250	---	10	---	138	187	54	73
10	250	---	---	10	151	205	59	80
10	250	---	16	16/20	165	224	65	88
10	250	300	---	---	185	251	---	---
10	250	---	25	---	262	355	---	---
10	250	---	40	30	291	395	---	---
12	300	150	---	---	145	197	---	---
12	300	---	10	---	130	176	---	---
12	300	---	---	10	108	146	---	---
12	300	---	16	---	157	213	---	---
12	300	---	---	16/20	117	159	---	---
12	300	300	---	---	250	339	---	---
12	300	---	25	---	236	320	---	---
12	300	---	40	30	262	355	---	---

Recommended Torque Values for Standard Type Rupture Discs  
(Light Lip and Heavy Lip)

TABLE 1

SIZE		COMPANION FLANGE RATING			DISCS WITHOUT 30° SEAT B.D.I. ASSEMBLY		DISCS WITH 30° SEAT B.D.I. ASSEMBLY OR TEFLON LINERS	
IN	MM	ANSI	DIN	JIS	TORQUE (FT•LB)	TORQUE (N•m)	TORQUE (FT•LB)	TORQUE (N•m)
14	350	150	---	---	230	312	---	---
14	350	---	10	---	136	184	---	---
14	350	---	---	10	149	202	---	---
14	350	---	16	---	163	221	---	---
14	350	---	---	16/20	204	277	---	---
14	350	300	---	---	250	339	---	---
14	350	---	25	30	328	445	---	---
14	350	---	40	---	361	489	---	---
16	400	150	---	---	230	312	---	---
16	400	---	10	10	217	294	---	---
16	400	---	16	---	245	332	---	---
16	400	---	---	16/20	272	369	---	---
16	400	300	---	---	255	346	---	---
16	400	---	25	---	331	449	---	---
16	400	---	40	30	361	489	---	---
18	450	150	---	---	280	380	---	---
18	450	---	---	10	188	255	---	---
18	450	---	---	16/20	294	399	---	---
18	450	300	---	---	270	366	---	---
20	500	150	---	---	350	475	---	---
20	500	---	10	10	294	399	---	---
20	500	---	16	16/20	367	498	---	---
20	500	300	---	---	320	434	---	---
20	500	---	25	---	399	541	---	---
20	500	---	40	---	472	640	---	---
24	600	150	---	---	465	630	---	---
24	600	---	10	---	395	536	---	---
24	600	---	---	10	366	496	---	---
24	600	---	16	---	483	655	---	---
24	600	---	---	16/20	439	595	---	---
24	600	300	---	---	465	630	---	---
24	600	---	25	---	527	714	---	---

**C. Installation of the Union Type Assembly into the System (See Figure H)**

1. Assure that the unit being installed is compatible with current system operating conditions.
2. Before installing the Union Type assembly into the system, clean mating threads of all grit, dirt, or foreign material to ensure proper seal.
3. When installing the assembly into the system, do not tighten or loosen seal between holder inlet and holder outlet, for this could cause damage to the rupture disc or cause premature failure.

Figure 'H'

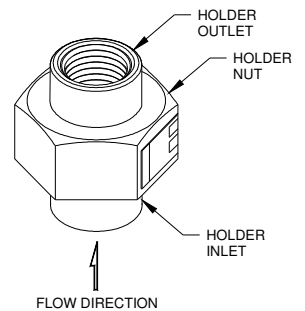



## V. Preventative Maintenance

1. Risk assessment and an annual rupture disc replacement are recommended. Rupture disc service life is determined by system operating conditions. The effects of severe pressure/vacuum cycles, corrosion, temperature variations, or other adverse conditions must be evaluated by the user through actual service experience to determine optimal service life.
2. **IF THE RUPTURE DISC IS NOT REPLACED PERIODICALLY WHEN EXPOSED TO THESE CONDITIONS, PREMATURE FAILURE OF THE RUPTURE DISC MAY OCCUR, THEREBY DISCHARGING THE PROCESS MEDIA.**
3. To avoid extended downtime, maintain three spare rupture discs in stock at all times for each holder in use. The number of spares required ultimately will be determined by service conditions.

## VI. Customer Service

If you wish to discuss your application, installation, or maintenance, please contact the Customer Service Department at one of the addresses shown below.

### B.D.I. ALARM SYSTEM OPERATING LIMITS

TEMPERATURE: -40° F to + 400° F  
(-40° C to + 204° C)

MAX CURRENT: 50 Milli Amps  
MAX VOLTAGE: 24 VDC RMS

FULFILLS THE REQUIREMENTS OF DIRECTIVE 94/9/EC (ATEX) FOR: Equipment or protective system intended for use in potentially explosive atmospheres.

Conformity assessment performed by Notified Body no. 0359,  
Intertek Testing and Certification Limited, Leatherhead, Surrey, UK.

BURST DISC INDICATOR (B.D.I.<sup>®</sup>): Sizes 25mm through 900mm (1 inch through 36 inches)

Marked:  II 1 G Ex ia IIC Tx Ga  
II 1 D Ex ia IIIC Tx Da  
(Tamb = -40° C to +204° C)

EC Type Examination Certificate: ITS13ATEX27734X

THE MAXIMUM INTRINSICALLY SAFE INPUT PARAMETERS ARE AS FOLLOWS:

Ui = 24V dc  
Ii = 50 mA  
Pi = 0.3W

THE EQUIVALENT PARAMETERS ARE:

Ci = 0  
Li = 0

SPECIAL CONDITIONS FOR SAFE USE:

1. The arrangements for connection of the external circuits must comply with the requirements of clause 6.2 of EN 60079-11:2012.
2. The component must be housed in an enclosure which provides a degree of protection of at least IP 20.
3. The final installation shall comply with the 500 volt electrical strength test requirement of clause 6.3.12 of EN 60079-11:2012.
4. The installation shall prevent electrostatic charging of the BDI strip, which is non-conductive and may exceed the surface area limitations of EN 60079-0:2012 clause 7.4.2.



**Continental Disc<sup>®</sup>  
Corporation**

**Performance Under Pressure<sup>®</sup>**



First Certified in 1992



If stamped, this product is built in accordance with the requirements of the ASME Boiler and Pressure Vessel Code, Section VIII, Division 1.

**China Manufacture License**  
Products are in full compliance with the provisions of the Peoples Republic of China Import Regulations for Boiler and Pressure Vessel safety devices.



**3A Sanitary Standards Stamp**  
If stamped, this product is in full compliance with the 3A standards, Serial #60-00, of the International Association of Milk, Food, and Environmental Sanitarians, Inc.



**European Union CE Mark**  
If stamped, this product is certified to conform to the essential requirements of the Pressure Equipment Directive.

Continental Disc Corporation has representatives located throughout the world.  
Contact the office nearest you for the authorized representative in your area.

 	<p><b>HEADQUARTERS //</b> 3160 W. Heartland Drive Liberty, MO 64068 USA Ph (816) 792 1500   Fax (816) 792 2277 sales@contdisc.com</p>	<p><b>contdisc.com</b></p>
<p><b>THE NETHERLANDS</b> Energieweg 20 2382 NJ Zoeterwoude-Rijndijk The Netherlands Ph +(31) 71 5412221   Fax +(31) 71 5414361 cdcnl@contdisc.com</p>	<p><b>CHINA</b> Room 910, Tower B, COFCO Plaza No. 8 JianGuoMenNei Avenue Beijing [100005], P.R. China Ph +(86) 10 522 4885   Fax +(86) 10 6522 2885 cdcchina@contdisc.com</p>	<p><b>INDIA</b> 423/P/11, Mahagujarat Industrial Estate, Moraiya, Sarkhej-Bavla Road, Ahmedabad [GJ] 382213 INDIA Ph +(91) 2717 619 333   Fax +(86) 10 6522 2885 gcempl@contdisc.com</p>

Continental Disc Corporation reserves the right to alter the information in this publication without notice.

Reproduction without written permission prohibited. ©1994, 1995, 1996, 1998, 2001, 2003, 2004, 2008, 2009, 2010, 2011, 2012, 2013

Printed in U.S.A.

Continental Disc Corporation