



**Continental Disc®
Corporation**

Preparation and Installation of the RCS Rupture Disc Assembly

WARNING

USER SHOULD READ AND THOROUGHLY UNDERSTAND THESE INSTRUCTIONS BEFORE INSTALLING RUPTURE DISC. THESE INSTRUCTIONS DO NOT PURPORT TO ADDRESS ALL OF THE SAFETY FACTORS ASSOCIATED WITH THE RUPTURE DISC'S USE IN SERVICE. IT IS THE RESPONSIBILITY OF THE USER TO ESTABLISH APPROPRIATE SAFETY, HEALTH, AND TRAINING MEASURES FOR THEIR PERSONNEL INSTALLING, SERVICING, OR WORKING IN AN AREA WHERE RUPTURE DISC ASSEMBLIES ARE IN USE. SERVICE AND/OR MAINTENANCE ON OR AROUND THE RUPTURE DISC DEVICE MUST NOT BE PERFORMED WHILE THE DEVICE IS SUBJECTED TO OPERATING PRESSURES AND/OR TEMPERATURES.

IT IS THE USER'S SOLE RESPONSIBILITY FOR DESIGN AND PLACEMENT OF RUPTURE DISCS WITHIN THEIR FACILITY AND UPON THE EQUIPMENT UPON WHICH THE RUPTURE DISC OF USER'S SELECTION IS TO BE LOCATED. IT IS USER'S SOLE RESPONSIBILITY FOR THE DESIGN OF ADEQUATE VENTING AND INSTALLATION OF ADEQUATE VENT PIPING OR DIRECTIONAL FLOW AFTER RUPTURE OCCURS WITH THE RUPTURE DISC AS INTENDED. WHEN SIZE IS SPECIFIED, CONTINENTAL DISC CORPORATION ASSUMES THAT ADEQUATE PROVISIONS HAVE BEEN MADE BY PURCHASER FOR PROPER VENTING OF A SYSTEM TO RELIEVE THE SPECIFIC PRESSURE. LOCATE RUPTURE DISC WHERE PEOPLE OR PROPERTY WILL NOT BE EXPOSED TO THE SYSTEM DISCHARGE IN CASE OF RUPTURE. VENT TOXIC OR FLAMMABLE FUMES OR LIQUIDS TO A SAFE LOCATION TO PREVENT PERSONAL INJURY OR PROPERTY DAMAGE.

IT IS THE USER'S SOLE RESPONSIBILITY TO SPECIFY THE BURST PRESSURE RATING OF A RUPTURE DISC AT A COINCIDENT TEMPERATURE AT WHICH THE RUPTURE DISC IS TO BE USED. A RUPTURE DISC IS A TEMPERATURE SENSITIVE DEVICE. THE BURST PRESSURE OF THE RUPTURE DISC IS DIRECTLY AFFECTED BY ITS EXPOSURE TO THE COINCIDENT TEMPERATURE. GENERALLY, AS THE TEMPERATURE AT THE RUPTURE DISC INCREASES, THE BURST PRESSURE DECREASES; INVERSELY, AS THE TEMPERATURE AT THE RUPTURE DISC DECREASES, THE BURST PRESSURE MAY INCREASE. FAILURE TO PROPERLY UTILIZE A RUPTURE DISC AT THE SPECIFIED COINCIDENT TEMPERATURE COULD CAUSE PREMATURE FAILURE OR OVERPRESSURIZATION OF A SYSTEM.

THE INSTANTANEOUS RELEASE OF PRESSURE FROM THE RUPTURE DISC CAN CREATE VIOLENT NOISES DUE TO THE DISCHARGE AT SONIC VELOCITY. IT IS THE USER'S SOLE RESPONSIBILITY TO PROTECT AGAINST HEARING DAMAGE TO ANY BYSTANDERS.

RUPTURE DISCS AND TAGS ARE MADE OF METAL FOILS OF VARYING THICKNESS. THE METAL EDGES MAY BE SHARP. PERSONNEL INSTALLING OR EXAMINING THE RUPTURE DISCS SHOULD PROTECT AGAINST CUTS OR INJURY WHEN HANDLING THE RUPTURE DISC. DO NOT LIFT A RUPTURE DISC BY ITS ATTACHED TAG.

PARTICLES MAY BE DISCHARGED WHEN THE RUPTURE DISC RUPTURES. THESE PARTICLES MAY BE PART OF THE RUPTURE DISC ITSELF, OR OTHER ENVIRONMENTAL MATTER IN THE SYSTEM. IT IS THE USER'S SOLE RESPONSIBILITY TO ASSURE THAT THESE PARTICLES ARE DIRECTED TO A SAFE AREA TO PREVENT PERSONAL INJURY OR PROPERTY DAMAGE.

THERE IS NO GUARANTEE OF RUPTURE DISC LIFE. SUCH LIFE SPAN IS AFFECTED BY CORROSION, CREEP AND FATIGUE, AND PHYSICAL DAMAGE. THESE CONDITIONS WILL DERATE THE RUPTURE DISC TO A LOWER SET PRESSURE. THE CUSTOMER AND/OR USER SHOULD BE PREPARED TO HANDLE PREMATURE FAILURE OF THE RUPTURE DISC. THE MEDIA OR OTHER ENVIRONMENTAL CONDITIONS SHOULD NOT ALLOW ANY BUILDUP OR SOLIDIFICATION OF MEDIA TO OCCUR ON A RUPTURE DISC. THIS MAY INCREASE THE PRESSURE SETTING OF THE RUPTURE DISC.

CUSTOMER AND/OR ITS INSTALLER SHALL BE SOLELY RESPONSIBLE FOR THE PROPER INSTALLATION OF SELLER'S HOLDERS AND RUPTURE DISCS INTO A SYSTEM. CUSTOMER AND/OR ITS INSTALLER SHALL BE SOLELY RESPONSIBLE FOR IMPROPER INSTALLATION AND PHYSICAL DAMAGE RESULTING THEREFROM, INCLUDING BUT NOT LIMITED TO, DAMAGE RESULTING FROM LEAKAGE, IMPROPER TORQUING OR SEATING OF A RUPTURE DISC OR FAILURE TO FOLLOW INSTALLATION INSTRUCTIONS WHERE PROVIDED.

RUPTURE DISCS ARE PRECISION SAFETY DEVICES AND MUST BE INSTALLED PROPERLY. RUPTURE DISCS MUST BE INSTALLED BY TRAINED, KNOWLEDGEABLE INSTALLERS AND ONLY WITHIN ENVIRONMENTS SUITABLE AND APPROPRIATE FOR A RUPTURE DISC. CARE MUST BE USED IN A FACILITY'S DESIGN TO PROTECT BOTH THE RUPTURE DISC FROM INADVERTENT DAMAGE WHICH COULD CAUSE ITS PREMATURE RELEASE AND TO PROTECT INDIVIDUALS EXPOSED TO HAZARDS CREATED BY SUCH SUDDEN RELEASE.

PROPER INSTALLATION OF A RUPTURE DISC IS CRITICAL TO PERFORMANCE AND TO SAFETY. FAILURE TO PROVIDE PROPER SEATING OF A RUPTURE DISC MAY AFFECT RUPTURE DISC PERFORMANCE, BURST PRESSURE ACCURACY AND MAY RESULT IN ITS PREMATURE FAILURE.

I. Safety Precautions Before Installation

1. The RCS rupture disc is a precision instrument and must be handled with extreme care. Rupture discs should be installed only by qualified personnel familiar with rupture discs and proper piping practices.
2. The score on the concave side of the rupture disc dome is a factory installed precision score. The indentation at the base of the rupture disc dome is a factory installed precision indentation *for 10" and larger* RCS rupture discs (Refer to Fig A). Do not install rupture disc if there is any damage in the dome area. A damaged rupture disc is any rupture disc with visible nicks or dents in the dome.
3. Continental Disc Corporation does not recommend reinstalling a rupture disc that has been removed from the holder as reinstallation may adversely affect the joint sealing capabilities and/or performance of the rupture disc.
4. See rupture disc tag to verify set pressure, operating temperature, and all other operating parameters.

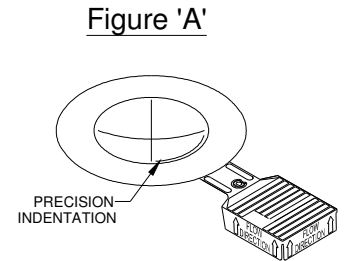

II. Preparation of Holders for Installation

New Installation

Clean all foreign material from the rupture disc sealing area of both the holder inlet and outlet.

Replacement Installation

1. If the Burst Disc Indicator (B.D.I.®) Alarm System is used, disconnect the alarm strip from the monitor by unplugging the B.D.I. connector from the lead wire connector.
2. Remove the holder from the system and place on a flat surface.
3. Disassemble the holder by loosening the pre-assembly screws or by removing the cap screws (sizes 10" - 32") on the holder outlet. For pre-torque holders, remove the flange screws. Lift the holder outlet up and set aside; then remove the burst rupture disc.
4. Clean the rupture disc sealing area of both the holder inlet and outlet. These surfaces must be completely clean and free of all rust, corrosion, and foreign material to ensure a proper seal. Use of solvents, steel wool, or fine emery cloth is permissible. Do not re-machine. Do not use scraper or abrasives.
5. Inspect the rupture disc sealing area for nicks, scratches, or pitting. If any of these conditions are present, consult the factory for repair.
6. Remove any adhered gasket material from previous installation.

III. Assembly of the Rupture Disc and Holder

RCS Insert Holder assembly components are illustrated in the proper installation sequence (see Figure B).

1. If the B.D.I. Alarm System is to be used, refer to the Universal B.D.I. Assembly installation instructions for additional details.
2. Carefully remove and discard any shipping protectors furnished with rupture discs or holder. **DO NOT INSTALL A SHIPPING PROTECTOR IN A HOLDER ASSEMBLY.**
3. Place the holder inlet on a flat surface with the alignment pins pointing up.

NOTE: *10" and larger* RCS holders do not have alignment pins.

4. Place the rupture disc over the pins with the dome side down.
5. Position the holder outlet carefully onto the alignment pins as shown, ensuring that the rupture disc is not damaged.
6. Fasten the assembly together by tightening the pre-assembly screws or by replacing and tightening the pre-assembly cap screws.

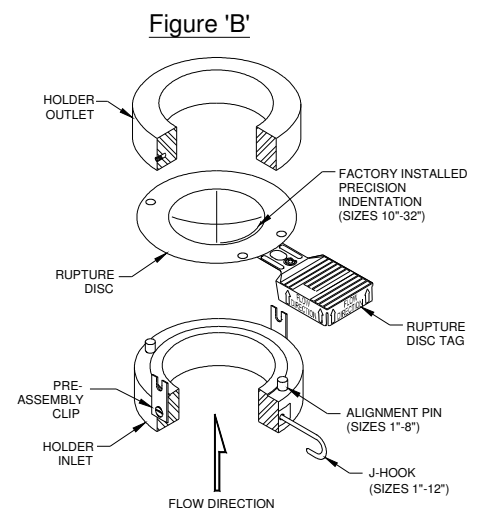

RCS Full Bolted Pre-torqued Holder assembly component parts are illustrated in the proper installation sequence (see Figure C).

1. If the B.D.I. Alarm System is to be used, refer to the Universal B.D.I. Assembly installation instructions for additional details.
2. Carefully remove and discard any shipping protectors furnished with rupture discs or holder. **DO NOT INSTALL A SHIPPING PROTECTOR IN A HOLDER ASSEMBLY.**
3. Place the holder inlet on a flat surface with the alignment pins pointing up.
4. Place the rupture disc over the pins with the dome side down.
5. Position the holder outlet carefully onto the alignment pins as shown, ensuring that the rupture disc is not damaged.
6. Fasten the assembly together by installing lightly oiled, free running flange screws to finger tightness. Using a cross torquing pattern (see Figure D), torque each screw with a calibrated torque wrench at 20% increments of recommended torque value shown in Table 1. Repeat 20% increments and cross torquing pattern until final torque value is achieved. Recheck all screws in rotational sequence at final torque value. These values are based on using the alloy steel flange screws provided which have a minimum yield strength of 158,000 psi. The use of screws with lower strength will prove unsatisfactory.

NOTE: WHEN INSTALLING RUPTURE DISC INTO EXISTING HOLDERS, USE RUPTURE DISC HOLDER MANUFACTURER'S RECOMMENDED CAP SCREW AND STUD TORQUE VALUES.

IV. Installation of the RCS Assembly Into the System (See Figure E or F)

1. Before placing the assembly into the system, ensure that the companion flange gasket surfaces are clean and free of all rust, corrosion, and foreign material.
2. For sizes 1" through 12" a J-Hook is provided in the holder inlet to ensure correct installation of the assembly relative to flow direction. Prior to installation of the assembly, the corresponding inlet companion flange must be drilled to accommodate the J-Hook. Refer to the J-Hook Installation Guide for locating and drilling specifications. NOTE: If replacing another manufacturer's holder, the corresponding inlet companion flange must be re-drilled to accommodate the J-Hook in the Continental Disc holder inlet.
3. Install the RCS assembly and customer furnished gaskets **WITH ALL FLOW ARROWS POINTING IN THE PROPER FLOW DIRECTION** and the J-Hook inserted into the drilled companion flange.
4. If a Teflon® outlet protective cover is ordered, install it between the RCS rupture disc assembly and the gasket of the outlet companion flange.
5. Install lightly oiled free running studs and nuts to finger tightness. Using a cross torquing pattern (see Figure G, page 4), torque each nut with a calibrated torque wrench at 20% increments of recommended torque value (see Table 2). Repeat 20% increments and cross torquing pattern until final torque value is achieved. Recheck all nuts in rotational sequence at final torque value. These values are based on using gasket materials having a gasket factor of 2.75, gasket seating stress of 3,700 psi, and stud and nut material per ASME SA193-B7 and SA194-2H respectively, with a stress of up to 30,000 psi. The use of studs and nuts with lower strength may prove unsatisfactory.

*Teflon is a registered trademark of E.I. du Pont de Nemours and company used under license.

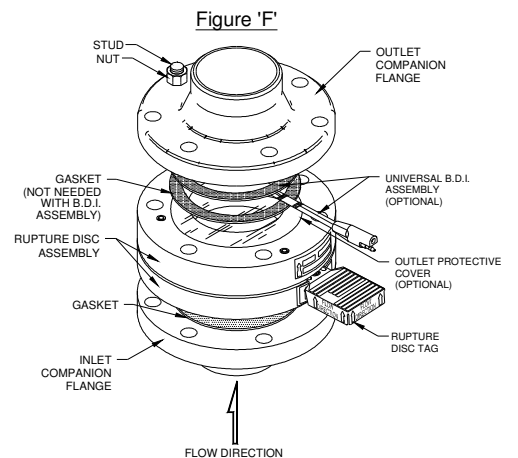
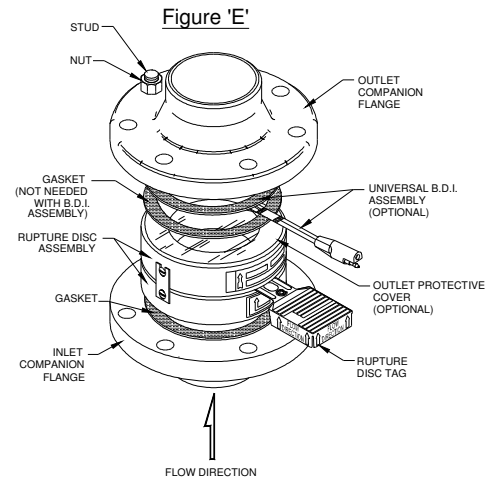
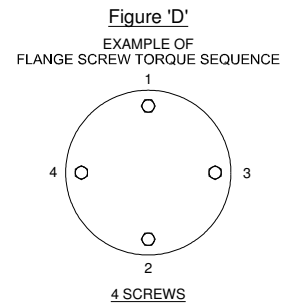
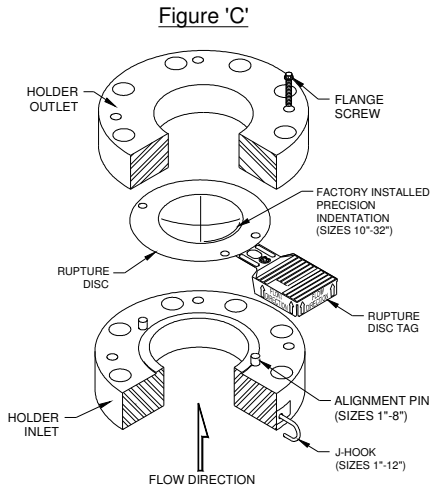

V. Preventative Maintenance

1. Risk assessment and an annual rupture disc replacement are recommended. Rupture disc service life is determined by system operating conditions. The effects of severe pressure/vacuum cycles, corrosion, temperature variations, or other adverse conditions must be evaluated by the user through actual service experience to determine optimal service life.
2. **IF THE RUPTURE DISC IS NOT REPLACED PERIODICALLY WHEN EXPOSED TO THESE CONDITIONS, PREMATURE FAILURE OF THE RUPTURE DISC MAY OCCUR, THEREBY DISCHARGING THE PROCESS MEDIA.**
3. To avoid extended downtime, maintain three spare rupture discs in stock at all times for each holder in use. The number of spares required ultimately will be determined by service conditions.

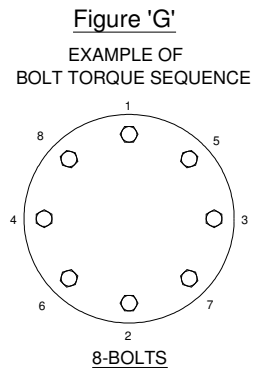

VI. Customer Service

If you wish to discuss your application, installation, or maintenance, please contact the Customer Service Department at one of the addresses shown on the last page of these instructions.

B.D.I. ALARM SYSTEM OPERATING LIMITS

TEMPERATURE: -40° F to + 400° F
(-40° C to + 204° C)

MAX CURRENT: 50 Milli Amps
MAX VOLTAGE: 24 VDC RMS

FULFILLS THE REQUIREMENTS OF DIRECTIVE 94/9/EC (ATEX) FOR: Equipment or protective system intended for use in potentially explosive atmospheres.

Conformity assessment performed by Notified Body no. 0359, Intertek Testing and Certification Limited, Leatherhead, Surrey, UK.

BURST DISC INDICATOR (B.D.I.[®]): Sizes 25mm through 900mm (1 inch through 36 inches)

Marked:  II 1 G Ex ia IIC Tx Ga
II 1 D Ex ia IIIC Tx Da
(Tamb = -40° C to +204° C)

EC Type Examination Certificate: ITS13ATEX27734X

THE MAXIMUM INTRINSICALLY SAFE INPUT PARAMETERS ARE AS FOLLOWS:

Ui = 24V dc
Ii = 50 mA
Pi = 0.3W

THE EQUIVALENT PARAMETERS ARE:

Ci = 0
Li = 0

SPECIAL CONDITIONS FOR SAFE USE:

1. The arrangements for connection of the external circuits must comply with the requirements of clause 6.2 of EN 60079-11:2012.
2. The component must be housed in an enclosure which provides a degree of protection of at least IP 20.
3. The final installation shall comply with the 500 volt electrical strength test requirement of clause 6.3.12 of EN 60079-11:2012.
4. The installation shall prevent electrostatic charging of the BDI strip, which is non-conductive and may exceed the surface area limitations of EN 60079-0:2012 clause 7.4.2.

Recommended Flange Screw Torque Values for RCS Rupture Discs Sizes 1" through 8" (Pre-Torqued Holder)

TABLE 1

SIZE		COMPANION FLANGE RATING			RECOMMENDED TORQUE VALUE	
IN	MM	ANSI	DIN	JIS	FT•LB	N•m
1	25	150	10/16	10/20	12	16
1	25	300/600	25/40	30/40	18	24
1-1/2	40	150	10/16	10/20	20	27
1-1/2	40	300/600	25/40	30/40	30	41
2	50	150	10/16	10/20	25	34
2	50	300/600	25/40	30/40	35	47
3	80	150	10/16	10/20	40	54
3	80	300/600	25/40	30/40	65	88
4	100	150	10/16	10/20	75	102
4	100	300	25/40	30	100	136
4	100	600	---	40	100	136
6	150	150	10/16	10/20	60	81
6	150	300	25/40	30	90	122
6	150	600	---	40	185	251
8	200	150	10/16	10/20	80	108
8	200	300	25/40	30	140	190

Recommended Companion Flange Torque Values for RCS Rupture Discs Sizes 1" through 32"

TABLE 2

SIZE		COMPANION FLANGE RATING			RECOMMENDED TORQUE VALUE		SIZE		COMPANION FLANGE RATING			RECOMMENDED TORQUE VALUE	
IN	MM	ANSI	DIN	JIS	FT•LB	N•m	IN	MM	ANSI	DIN	JIS	FT•LB	N•m
1	25	150	---	---	35	47	6	150	150	---	---	120	163
1	25	---	10/16	---	33	45	6	150	---	10/16	10	126	171
1	25	---	---	10/20	44	60	6	150	---	---	16/20	92	125
1	25	300/600	---	---	65	88	6	150	300	---	---	120	163
1	25	---	25/40	---	49	66	6	150	---	25/40	---	227	308
1	25	---	---	30/40	66	89	6	150	---	---	30	151	205
							6	150	600	---	---	275	373
1-1/2	40	150	---	---	35	47	6	150	--	---	40	260	352
1-1/2	40	---	10/16	10/20	44	60							
1-1/2	40	300/600	---	---	120	163	8	200	150	---	---	130	176
1-1/2	40	---	25/40	---	101	137	8	200	---	10	---	136	184
1-1/2	40	---	---	30/40	126	171	8	200	---	16	10	91	123
							8	200	---	---	16/20	100	136
2	50	150	---	---	65	88	8	200	300	---	---	180	244
2	50	---	10/16	10	66	89	8	200	---	25	30	194	263
2	50	---	---	16/20	33	45							
2	50	300/600	---	---	65	88	10	250	150	---	---	185	251
2	50	---	25/40	---	131	178	10	250	---	10	---	166	225
2	50	---	---	30/40	66	89	10	250	---	---	10	183	248
							10	250	---	16	16/20	200	271
3	80	150	---	---	65	88	10	250	300	---	---	260	352
3	80	---	10/16	10	33	45	10	250	---	25	---	369	500
3	80	---	---	16/20	41	56	10	250	---	40	30	409	555
3	80	300/600	---	---	120	163							
3	80	---	25/40	---	101	137	12	300	150	---	---	185	251
3	80	---	---	30/40	126	171	12	300	---	10	---	166	225
							12	300	---	---	10	137	186
4	100	150	---	---	65	88	12	300	---	16	---	200	271
4	100	---	10/16	10	66	89	12	300	---	---	16/20	150	203
4	100	---	---	16/20	82	111	12	300	300	---	---	375	508
4	100	300	---	---	120	163							
4	100	---	25/40	---	126	171	14	350	150	---	---	260	352
4	100	---	---	30	139	188	14	350	---	10	---	166	225
4	100	600	---	---	180	244	14	350	---	---	10	137	186
4	100	---	---	40	178	241	14	350	---	16	---	200	271
							14	350	---	---	16/20	150	203
							14	350	300	---	---	375	508

Recommended Companion Flange Torque Values for RCS Rupture Discs Sizes 1" through 32"

TABLE 2 (continued)

SIZE		COMPANION FLANGE RATING			RECOMMENDED TORQUE VALUE	
IN	MM	ANSI	DIN	JIS	FT•LB	N•m
16	400	150	---	---	260	352
16	400	---	10	10	246	334
16	400	---	16	---	276	374
16	400	---	---	16/20	307	416
16	400	300	---	---	485	658
18	450	150	---	---	375	508
18	450	---	---	10	252	342
18	450	---	---	16/20	315	427
20	500	150	---	---	375	508
20	500	---	10	10	262	355
20	500	---	16	16/20	397	538
24	600	150	---	---	485	658
24	600	---	10	---	367	498
24	600	---	---	10	382	518
24	600	---	16	---	504	683
24	600	---	---	16/20	458	621
30	750	150	---	---	485	658
32	800	150	---	---	875	1186

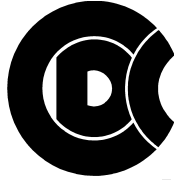

Continental Disc[®] Corporation

Performance Under Pressure[®]



First Certified in 1992



If stamped, this product is built in accordance with the requirements of the ASME Boiler and Pressure Vessel Code, Section VIII, Division 1.

China Manufacture License
Products are in full compliance with the provisions of the Peoples Republic of China Import Regulations for Boiler and Pressure Vessel safety devices.



3A Sanitary Standards Stamp
If stamped, this product is in full compliance with the 3A standards, Serial #60-00, of the International Association of Milk, Food, and Environmental Sanitarians, Inc.



European Union CE Mark
If stamped, this product is certified to conform to the essential requirements of the Pressure Equipment Directive.

Continental Disc Corporation has representatives located throughout the world.
Contact the office nearest you for the authorized representative in your area.

 	<p>HEADQUARTERS // 3160 W. Heartland Drive Liberty, MO 64068 USA Ph (816) 792 1500 Fax (816) 792 2277 sales@contdisc.com</p>	<p>contdisc.com</p>
<p>THE NETHERLANDS Energieweg 20 2382 NJ Zoeterwoude-Rijndijk The Netherlands Ph +[31] 71 5412231 Fax +[31] 71 5414361 cdcnl@contdisc.com</p>	<p>CHINA Room 910, Tower B, CDFCO Plaza No. 8 JianGuoMenNei Avenue Beijing (100005), P.R. China Ph +[86] 10 522 4885 Fax +[86] 10 6522 2885 cdcchina@contdisc.com</p>	<p>INDIA 423/P/11, Mahagujarat Industrial Estate, Moraiya, Sarkhej-Bavla Road, Ahmedabad (GJ) 382213 INDIA Ph +[91] 2717 619 333 Fax +[86] 10 6522 2885 gempl@contdisc.com</p>

Continental Disc Corporation reserves the right to alter the information in this publication without notice.

Reproduction without written permission prohibited.

©1996, 2000, 2001, 2003, 2004, 2008, 2009, 2010, 2011, 2012, 2013
Continental Disc Corporation

Printed in U.S.A.